

Last Modified: 7-13-2007		1.6 K
Service Category: Power Source/Network	Section: Battery/Charging	
Model Year: 2008	Model: ES350	Doc ID: RM000002EE2002X
Title: 2GR-FE CHARGING: GENERATOR: COMPONENTS (2008 ES350)		

[COMPONENTS](#)

[ILLUSTRATION](#)

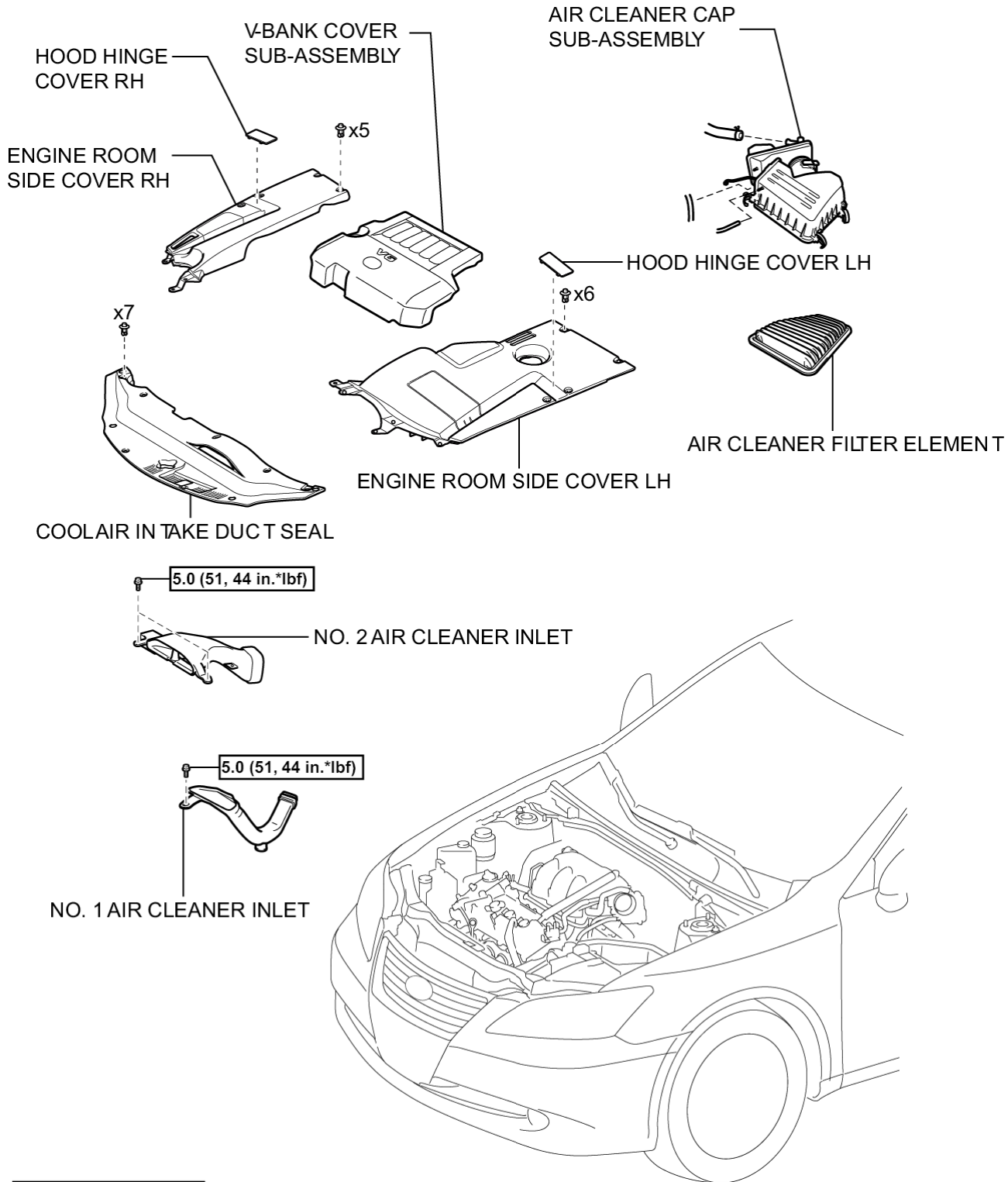

N*m (kgf*cm, ft.*lbf) : Specified torque

T

ILLUSTRATION

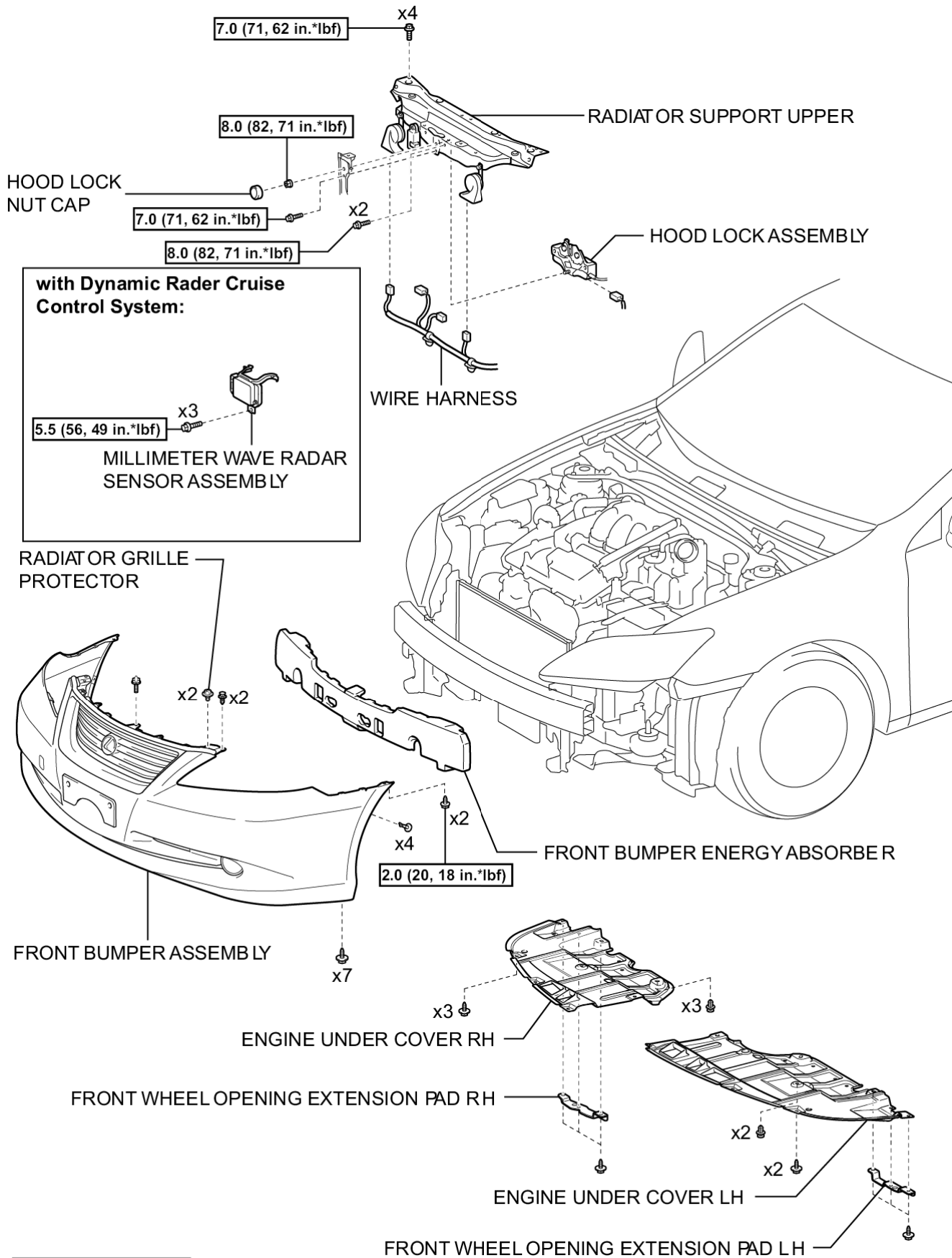

N*m (kgf*cm, ft.*lbf): Specified torque

T

ILLUSTRATION

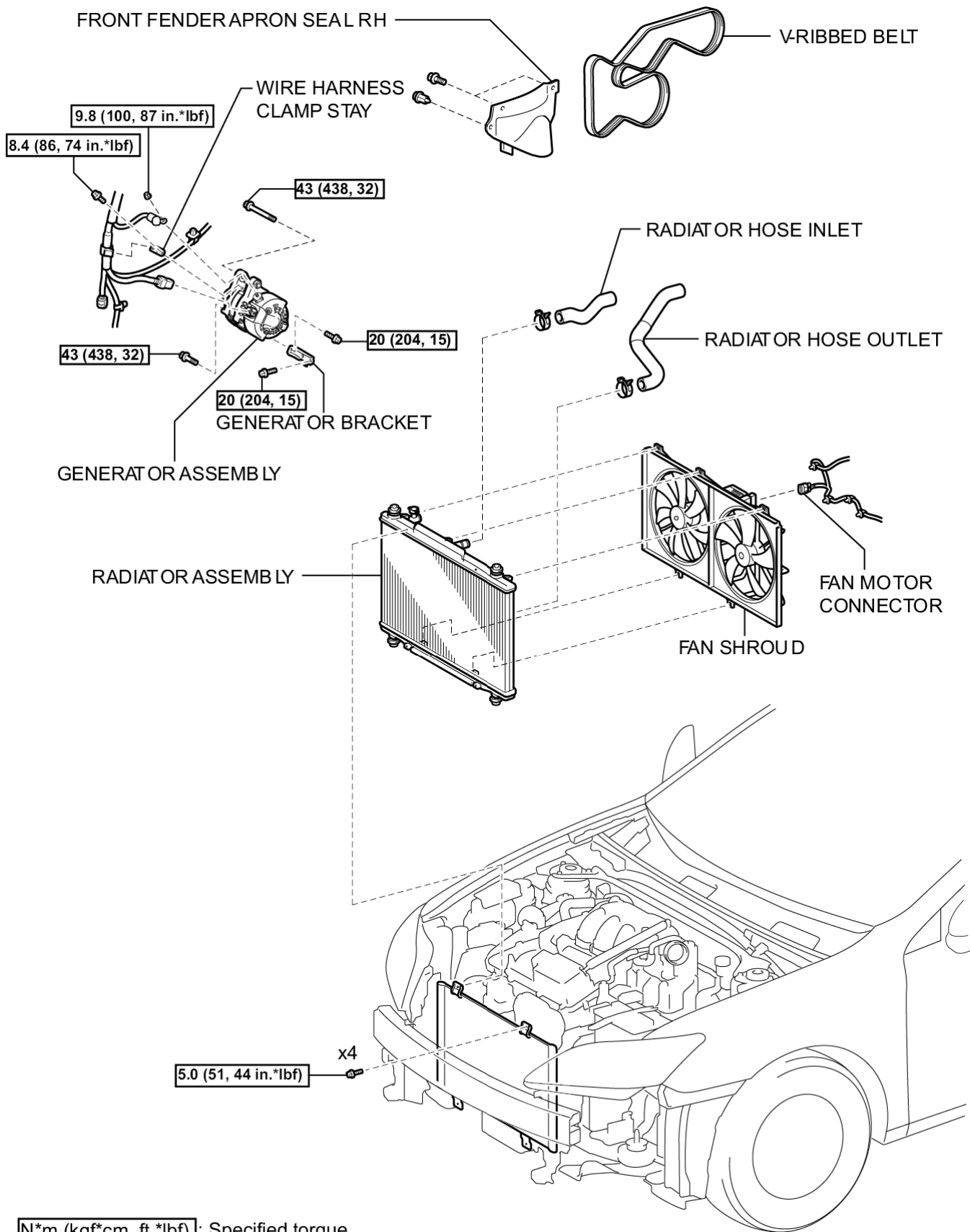

N*m (kgf*cm, ft.*lbf) : Specified torque

ILLUSTRATION

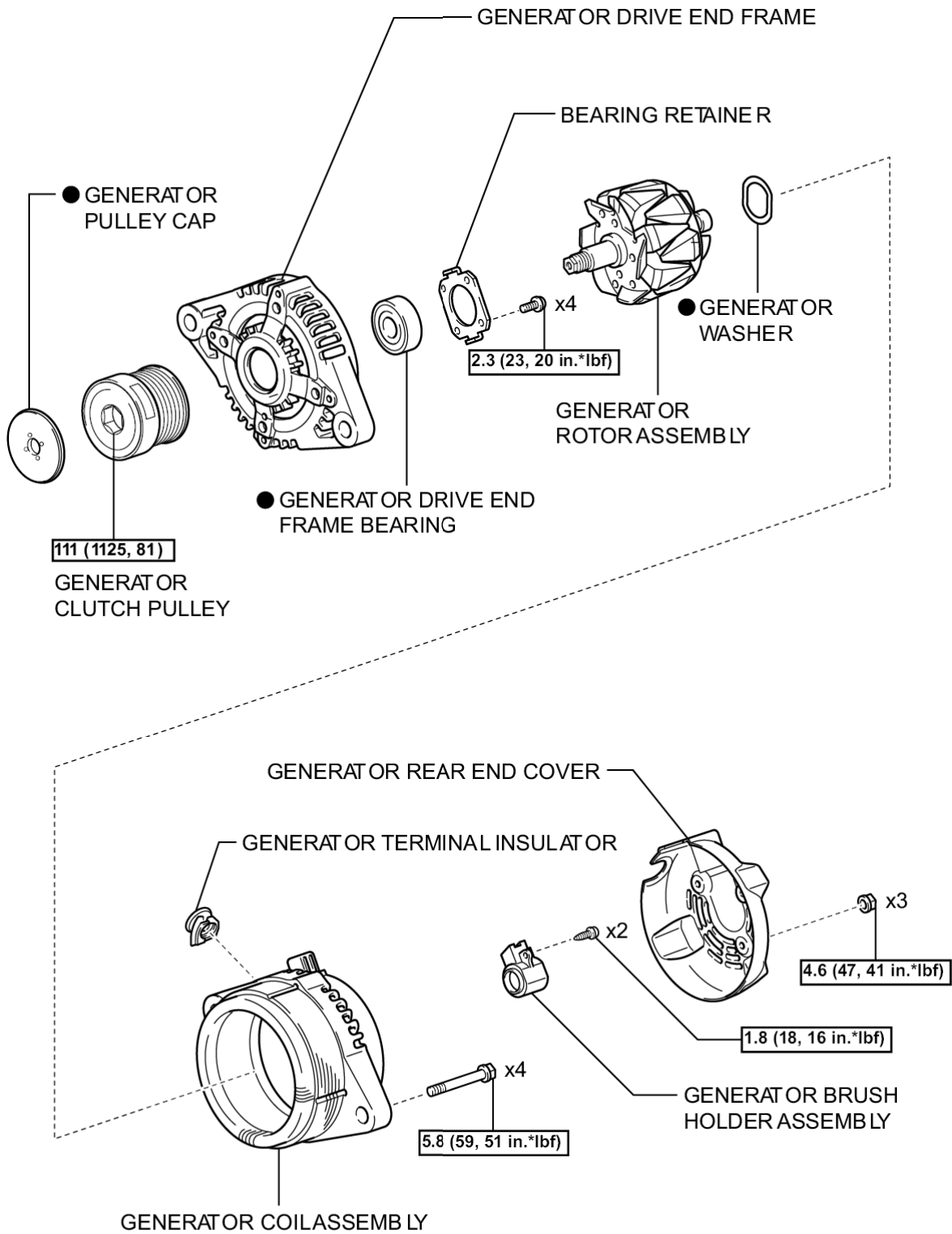

N*m (kgf*cm, ft.*lbf): Specified torque

● Non-reusable part

T

