

# Water Pump Inspection and Diagnosis Tips

**Service Category** Engine/Hybrid System

**Section** Cooling

**Market** USA

Lexus Supports  
ASE Certification 

## Applicability

YEAR(S)	MODEL(S)	ADDITIONAL INFORMATION
2007 – 2011	ES350, RX350	
2006	GS300	
2007 – 2011	GS350, GS450H	
2010 – 2011	GX460, HS250H, IS250C, IS350C, RX450H	
2006 – 2011	IS250, IS350	

## Introduction

This service bulletin contains water pump leak inspection and diagnostic tips.

## Warranty Information

OP CODE	DESCRIPTION	TIME	OFF	T1	T2
N/A	Not Applicable to Warranty	–	–	–	–

# Water Pump Inspection and Diagnosis Tips

## Diagnostic Procedure

Figure 1. Water Pump Construction

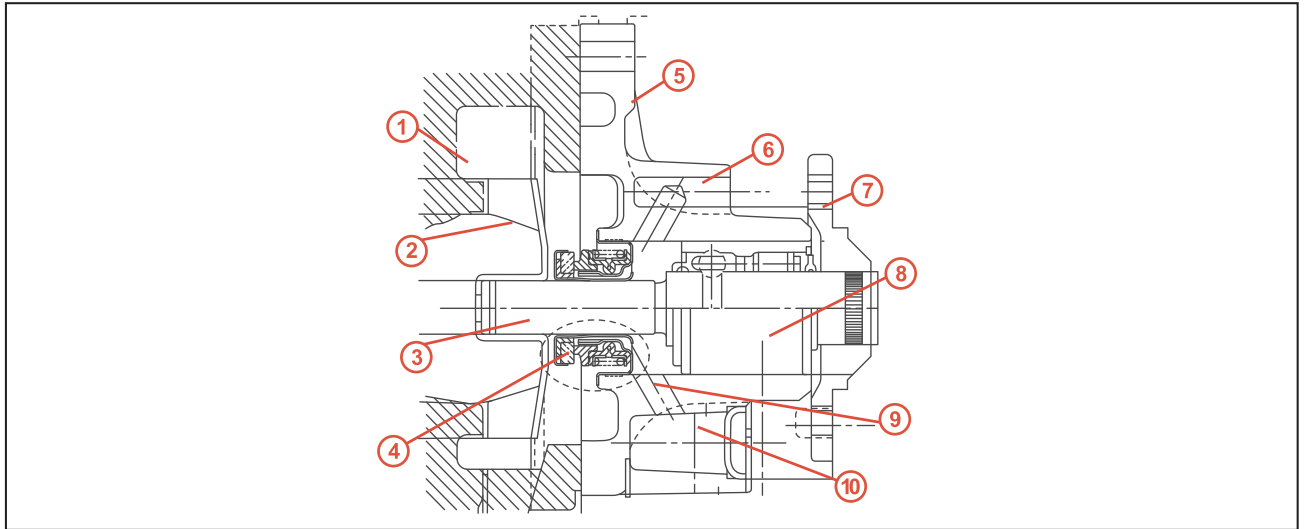

1	Engine Block
2	Impeller
3	Shaft
4	Mechanical Seal
5	Pump Body

6	Breather Hole
7	Pulley Seat
8	Bearing
9	Weep Hole
10	Fluid Catch Pocket

## Water Pump Inspection and Diagnosis Tips

### Diagnostic Procedure (Continued)

#### Water Pump Mechanical Seal

The water pump shaft is sealed by a mechanical type seal.

**Figure 2. Mechanical Seal Components**

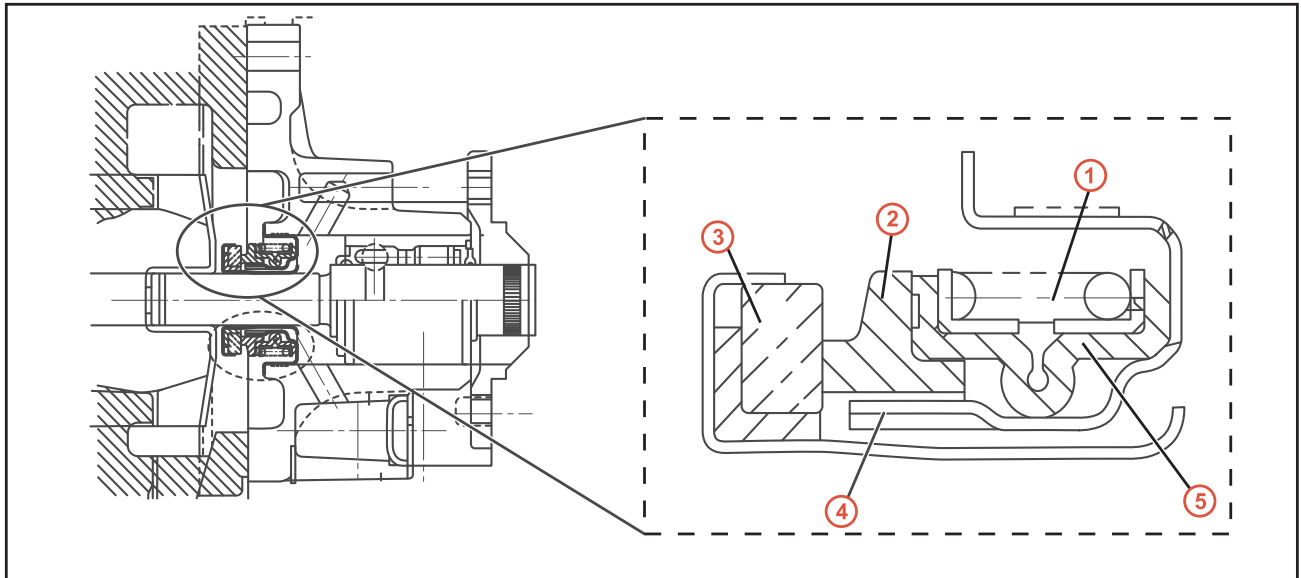

<b>1</b>	<b>Spring</b> – Applies pressure to the seal ring to ensure the seal ring and mating ring are in constant contact.
<b>2</b>	<b>Seal Ring</b> – Stationary sealing member in the water pump housing, held in place by the cartridge.
<b>3</b>	<b>Mating Ring</b> – Rotates with the water pump shaft and provides sealing surface for the seal ring.

<b>4</b>	<b>Cartridge</b> – Locates the seal ring and bellows in the water pump housing.
<b>5</b>	<b>Bellows</b> – Seals the cartridge and the seal ring.

#### **NOTE**

The seal and mating rings are lubricated by the surrounding coolant; a small amount of coolant leakage is normal.

#### Temporary Leaks

If debris becomes trapped between the mating ring and seal ring a small gap is formed. This allows coolant to bypass the mechanical seal, flow into the fluid catch pocket, and drain out of the weep hole. This condition is temporary and will no longer be present once the debris is crushed or works its way out of the seal. **Water pump replacement is not necessary.**

# Water Pump Inspection and Diagnosis Tips

## Diagnostic Procedure (Continued)

**Figure 3. Debris in Mechanical Seal**

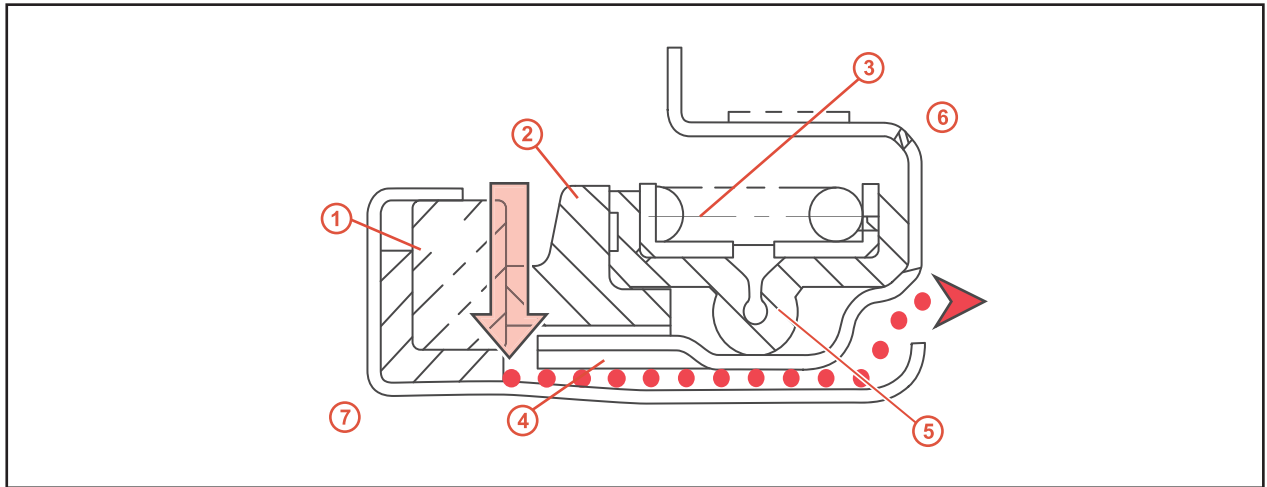

1	Mating Ring
2	Seal Ring: gap formed by debris
3	Spring
4	Cartridge

5	Bellows
6	Housing Side
7	Impeller Side

If debris was trapped between the seal ring and mating ring an abrasion mark may have been left on the mating ring surface. This abrasion mark does not affect sealing performance due to the large sealing surface of the mating ring. Once the debris is no longer present the mechanical seal performance will return to normal operation. **Water pump replacement is not necessary.**

**Figure 4. Mechanical Seal Mating Ring Sealing Surface**

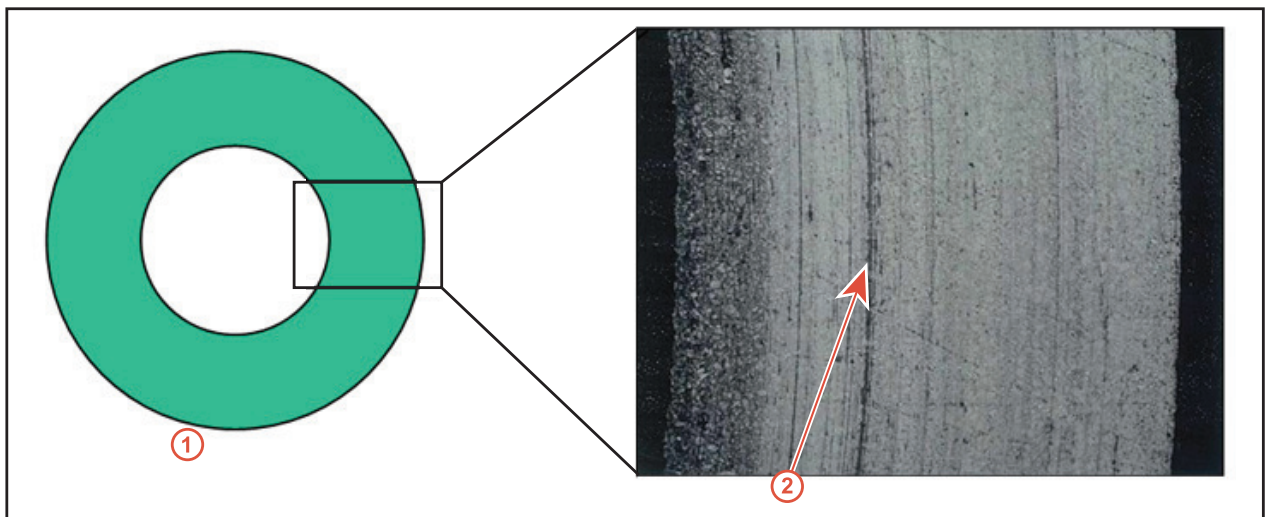

1	Mating Ring
---	-------------

2	Debris Abrasion Mark
---	----------------------

## Water Pump Inspection and Diagnosis Tips

### Diagnostic Procedure (Continued)

#### Inspection method:

**NOTE**

Before performing this inspection, confirm that coolant is not leaking from a component other than the water pump. If coolant appears to be leaking from another component, inspect that component following the appropriate repair manual procedure.

1. Visually inspect the water pump and coolant level in the coolant reservoir. Replace the water pump if any of the following conditions exist:
  - A. The coolant level is below the “low” level and the water pump appears to be leaking.
  - B. Water pump pulley/bearing has excessive free play or does not turn smoothly.
  - C. Heavy coolant deposits are present on both the water pump and surrounding components (i.e. pulleys, engine block, timing cover, under hood).

If the above conditions do not apply or amount of deposits are in question, the leak may have been temporary and additional inspection is necessary.

**Figure 5. Current Leak – Replace Water Pump**

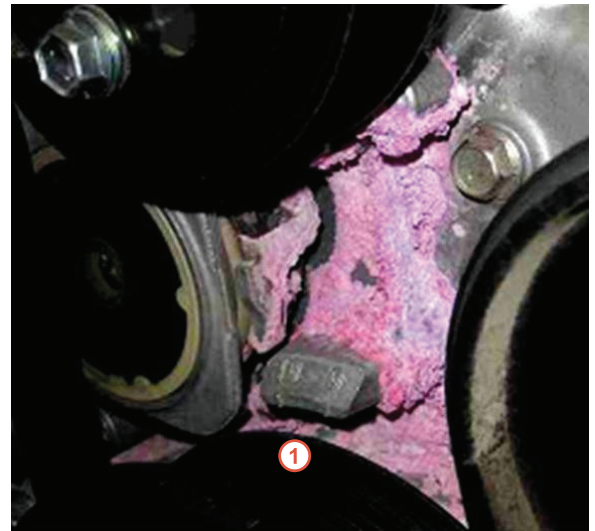

<b>1</b>	Heavy coolant deposits present on water pump and all surrounding components
----------	---

**Figure 6. Possible Temporary Leaks – Inspect Water Pump**



<b>1</b>	Thick coolant deposits present on water pump only
<b>2</b>	Moderate coolant deposits present on water pump only
<b>3</b>	Light coolant deposits present on water pump only

## Water Pump Inspection and Diagnosis Tips

### Diagnostic Procedure (Continued)

2. A paper towel should be used to determine if a leak is current, or was temporary due to debris that has now cleared.

Figure 7.



3. Apply a dry paper towel to the coolant deposits around the weep hole. If the paper towel remains dry the leak was temporary and the water pump does not need to be replaced. If the paper towel becomes wet the leak is current and the water pump should be replaced.

Figure 8.

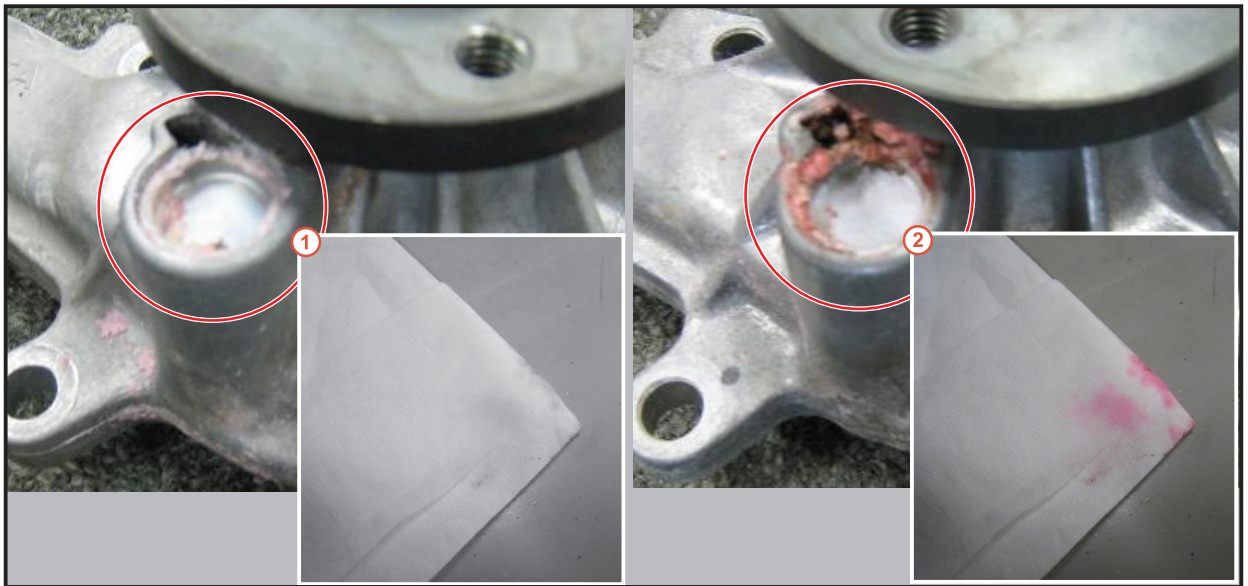

**1** Dry Paper Towel DO NOT Replace Water Pump

**2** Wet Paper Towel Replace Water Pump