

Last Modified: 7-13-2007		1.6 A
Service Category: Brake	Section: Parking Brake	
Model Year: 2008	Model: ES350	Doc ID: RM000000ZAC00HX
Title: PARKING BRAKE: PARKING BRAKE ASSEMBLY: DISASSEMBLY (2008 ES350)		

DISASSEMBLY

HINT:

- Use the same procedures for the RH side and the LH side.
- The procedures listed below are for the LH side.

1. REMOVE REAR WHEEL

2. SEPARATE REAR DISC BRAKE CALIPER ASSEMBLY

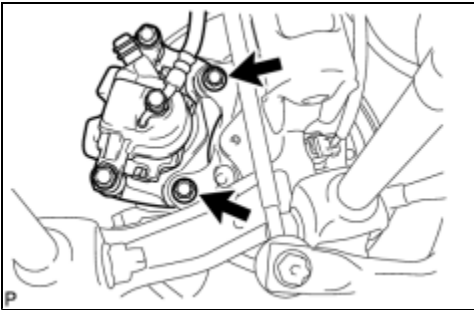

(a) Remove the 2 bolts and separate the rear disc brake caliper assembly.

HINT:

Do not disconnect the flexible hose from the disc brake caliper assembly.

3. REMOVE REAR DISC

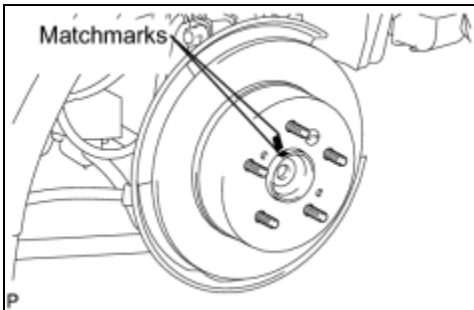

(a) Release the parking brake and place the matchmarks on the rear disc and the axle hub.

(b) Remove the rear disc.

HINT:

If the disc cannot be removed easily, turn the shoe adjuster until the wheel turns freely.

4. REMOVE PARKING BRAKE SHOE RETURN TENSION NO. 1 SPRING

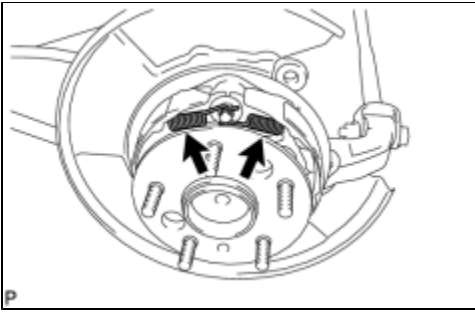

(a) Using needle-nose pliers, remove the 2 parking brake shoe return tension No. 1 springs.

5. REMOVE PARKING BRAKE SHOE STRUT

(a) Remove the parking brake shoe strut and the parking brake shoe strut compression spring.

6. REMOVE NO. 1 PARKING BRAKE SHOE ASSEMBLY

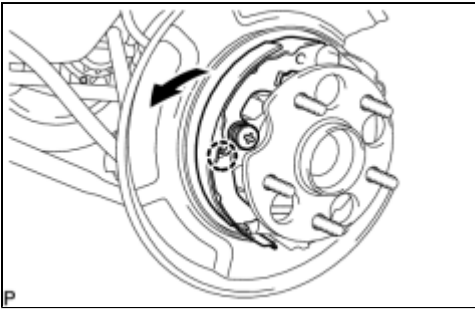

(a) Release the claw of the parking brake shoe hold down spring No. 1 cup.

(b) Remove the No. 1 parking brake shoe assembly as shown in the illustration.

(c) Remove the parking brake shoe hold down spring No. 1 cup, the parking brake shoe hold down spring, the parking brake shoe hold down spring No. 2 cup, and the parking brake shoe hold down spring No. 1 pin.

7. REMOVE PARKING BRAKE SHOE ADJUSTING SCREW SET

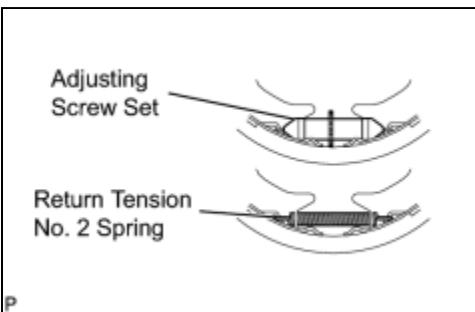

(a) Remove the parking brake shoe adjusting screw set.

(b) Remove the parking brake shoe return tension No. 2 spring.

8. REMOVE NO. 2 PARKING BRAKE SHOE ASSEMBLY

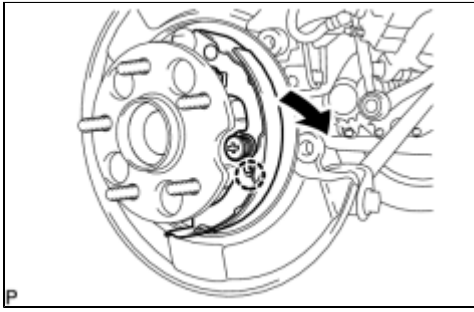

(a) Release the claw of the parking brake shoe hold down spring No. 1 cup.

(b) Remove the No. 2 parking brake shoe assembly as shown in the illustration.

(c) Remove the parking brake shoe hold down spring No. 1 cup, the parking brake shoe hold down spring, the parking brake shoe hold down spring No. 2 cup, and the parking brake shoe hold down spring No. 2 pin.

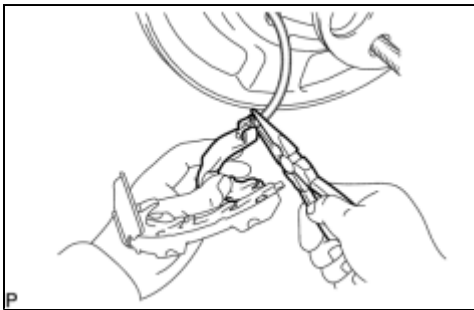

(d) Using needle-nose pliers, disconnect the No. 3 parking brake cable assembly from the parking brake shoe lever.

NOTICE:

Be careful not to damage the No. 3 parking brake cable assembly.

9. REMOVE PARKING BRAKE SHOE LEVER

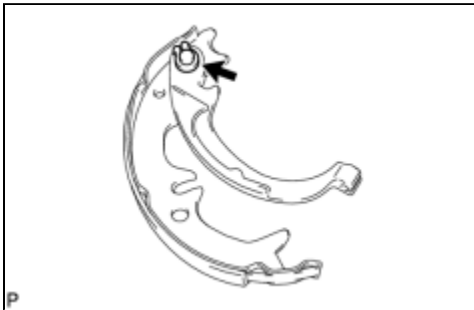

(a) Using a screwdriver, remove the C-washer, shim and the parking brake shoe lever.

10. REMOVE PARKING BRAKE SHOE GUIDE PLATE

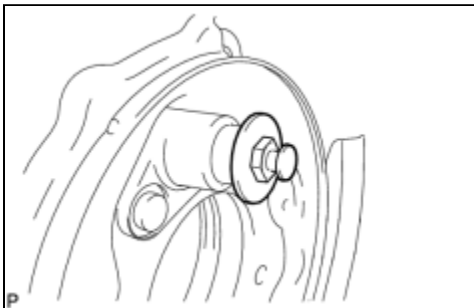

(a) Remove the parking brake shoe guide plate set bolt and the parking brake shoe guide plate.