

Last Modified: 7-13-2007		1.6 D
Service Category: Audio/Visual/Telematics		Section: Park Assist/Monitoring
Model Year: 2008	Model: ES350	Doc ID: RM000000VVD014X
Title: PARK ASSIST / MONITORING: INTUITIVE PARKING ASSIST SYSTEM: OPERATION CHECK (2008 ES350)		

OPERATION CHECK

1. SELF-CHECK FUNCTION INSPECTION

- Turn the engine switch on (IG).
- When the intuitive parking assist system is turned on, check that the following occurs: 1) after 0.1 milliseconds, the buzzer sounds for approximately 0.8 seconds, and 2) the system starts the obstacle detection operation.

HINT:

- If a sensor has an open circuit or a sensor's detection operation malfunctions because it is wet or frozen, a malfunction display is shown on the multi-information display or multi-display, and the buzzer sounds.
- When the sensor condition returns to normal, the system ends normal clearance sonar mode.
- If the clearance sonar main switch is on and the engine switch is turned on (IG), the buzzer does not sound.

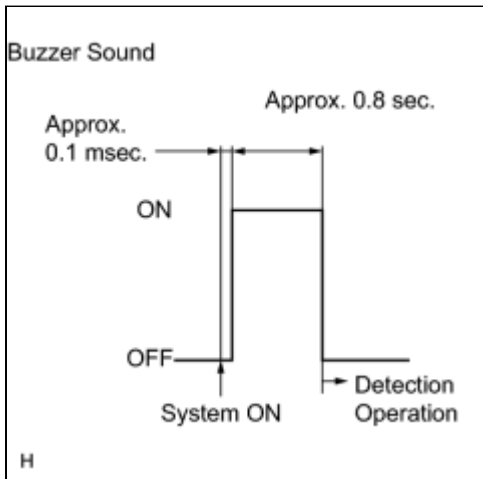

2. MALFUNCTION DISPLAY (MULTI-INFORMATION DISPLAY)

- Ultrasonic sensor open circuit

- If there is an open circuit between the ultrasonic sensor and the clearance warning ECU or if a sensor is malfunctioning, the malfunction is displayed as shown in the illustration.

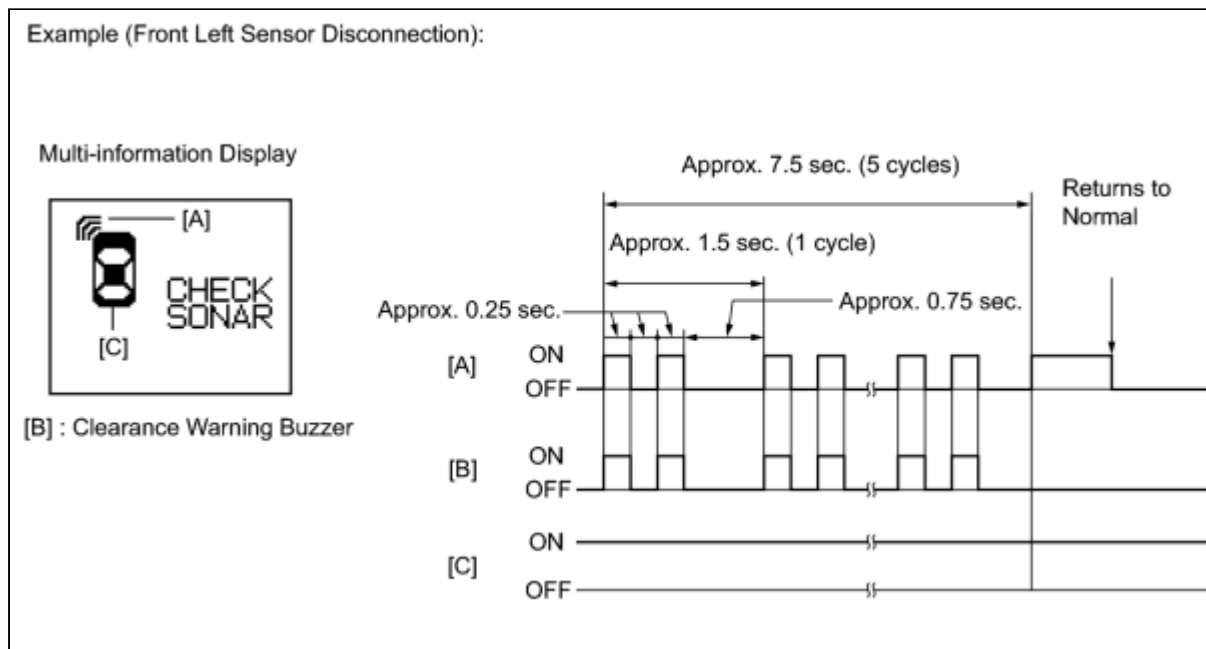

HINT:

- The example shows an open circuit in the ultrasonic sensor (front left sensor).
- If a sensor has an open circuit, refer to "Open circuit is displayed as a result of self-check" in the Problem Symptoms Table to inspect it.

(b) Ultrasonic sensor frozen

- (1) If a sensor is covered with foreign matter, such as mud or snow, the affected sensor is displayed as shown in the illustration.

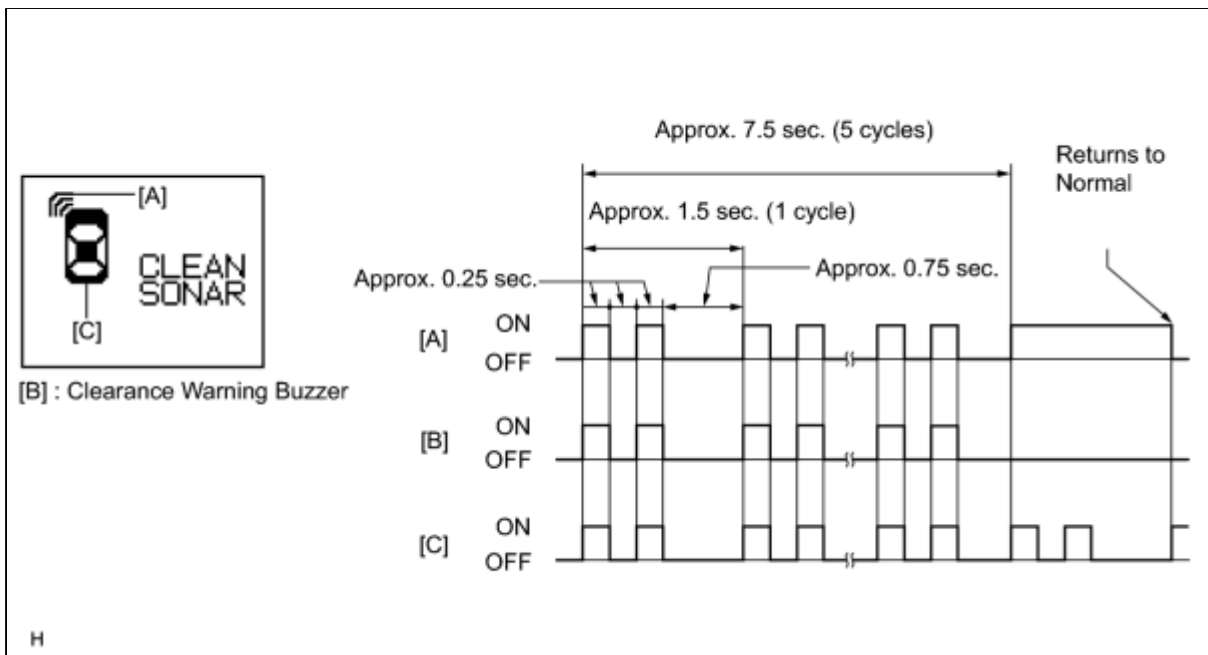
**HINT:**

- The example shows that the ultrasonic sensor (front left sensor) is covered with foreign matter.
- If "CLEAN SONAR" is displayed, cleaning the foreign matter from the sensor will return the sensor to normal.

3. MALFUNCTION DISPLAY (MULTI-DISPLAY)

(a) Ultrasonic sensor open circuit

- (1) If there is an open circuit between the ultrasonic sensor and the clearance warning ECU or if a sensor is malfunctioning, the malfunction is displayed as shown in the illustration.

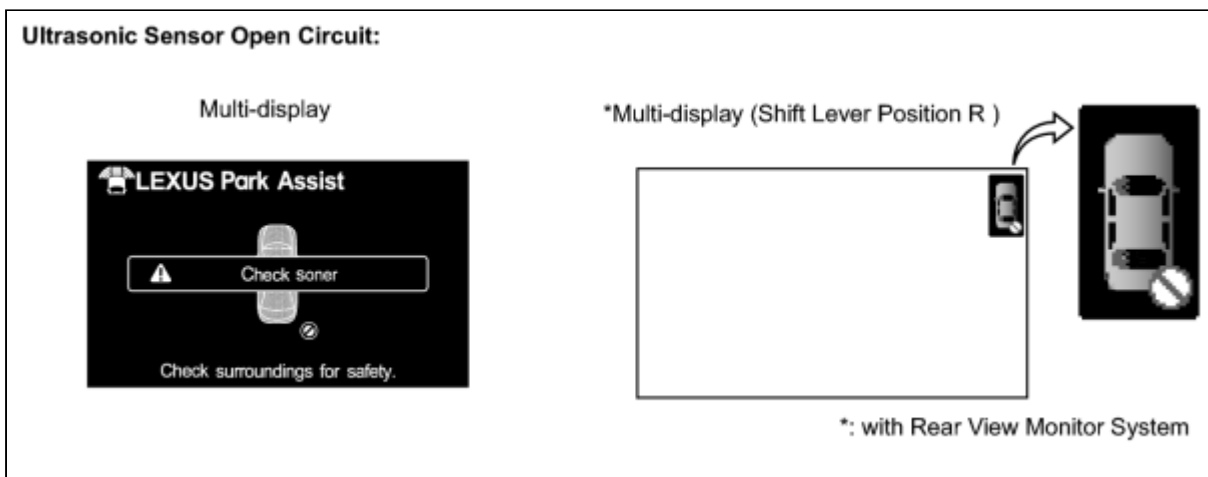
**HINT:**

- This example shows an open circuit in the ultrasonic sensor (rear right sensor).
- If a sensor has an open circuit, refer to "Open circuit is displayed as a result of self-check" in the Problem Symptoms Table to inspect it.

(b) Ultrasonic sensor frozen

- (1) If a sensor is covered with foreign matter, such as mud or snow, the affected sensor is displayed as shown in

the illustration.

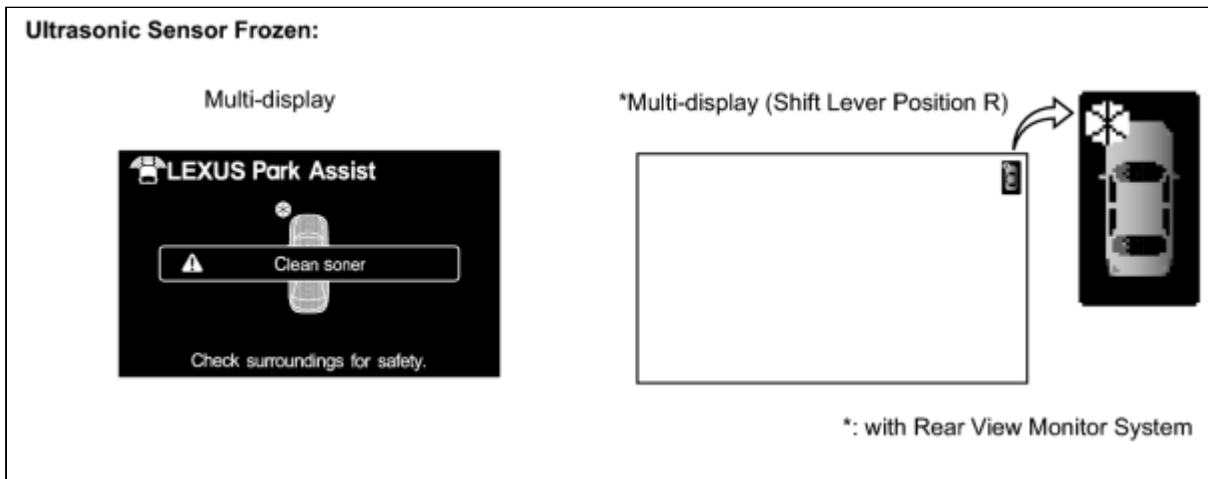

HINT:

- The example shows that the ultrasonic sensor (front left sensor) is covered with foreign matter.
- If "CLEAN SONAR" is displayed, cleaning the foreign matter from the sensor will return the sensor to normal.

4. DETECTION RANGE MEASUREMENT AND DISPLAY INSPECTION

(a) Detection range measurement

NOTICE:

Make sure the vehicle does not move by applying the parking brake firmly.

- (1) Turn the engine switch on (IG).
 - (2) Move the shift lever to the reverse position to check the ultrasonic sensors (rear sensors).
- (b) Turn the clearance sonar main switch on.
- (c) Move a ϕ 60 mm (2.36 in.) pole near each sensor to measure its detection range.
- (1) Measure the clearance sonar's detection range.

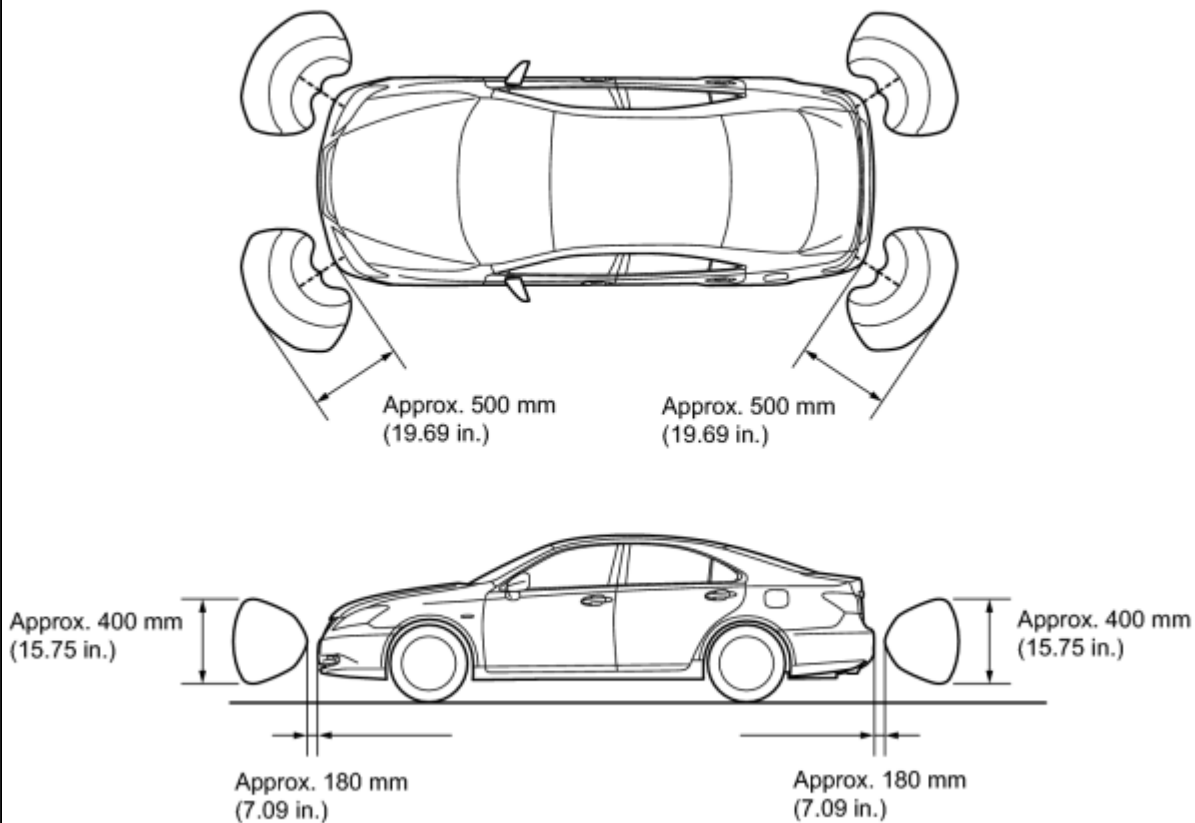
Clearance Sonar:

H

NOTICE:

These detection ranges are applicable when positioning the ϕ 60 mm (2.36 in.) pole parallel or perpendicular to the ground. The ranges vary depending on the measuring method and type of obstacle (such as walls).

(2) Measure the back sonar's detection range.

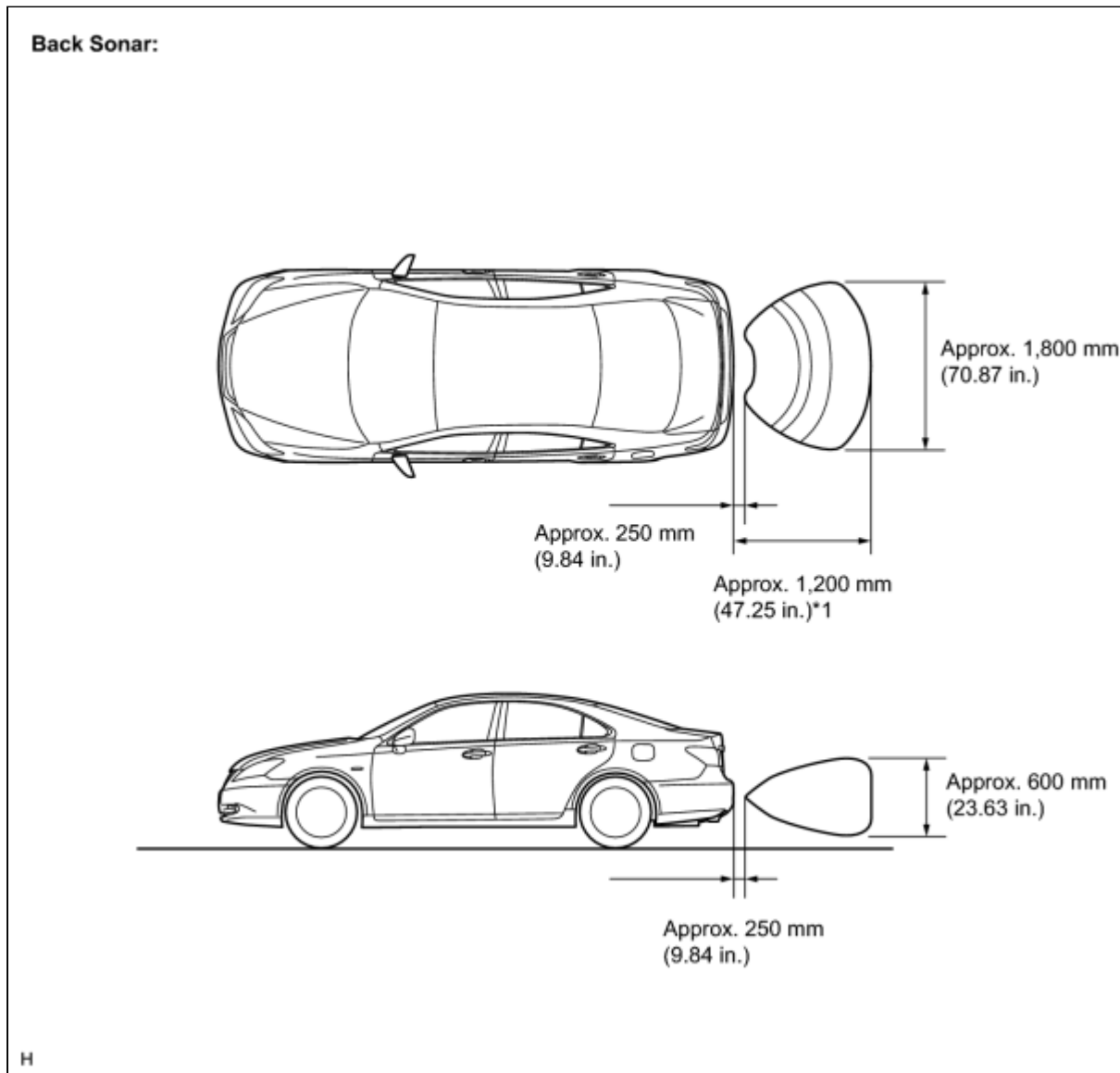
**NOTICE:**

- These detection ranges are applicable when positioning the ϕ 60 mm (2.36 in.) pole parallel or perpendicular to the ground. The ranges vary depending on the measuring method and type of obstacle (such as walls).
- *1: A pole with a diameter of approximately 60 mm (2.36 in.) can be detected within this detection area. If there is a cylinder-shaped object with a diameter of approximately 400 mm (15.74 in.), the detection area expands to approximately 1,500 mm (59.05 in.).

(d) When the ultrasonic sensors (front clearance sonar) have detected an obstacle, check the display and buzzer sound.

Operation condition:

ENGINE SWITCH	CLEARANCE SONAR MAIN SWITCH	SHIFT LEVER POSITION	VEHICLE SPEED
ON (IG)	ON	In any position except P	10 km/h (6 mph) or less

(1) Check the buzzer sound according to the waveform shown in the illustration.

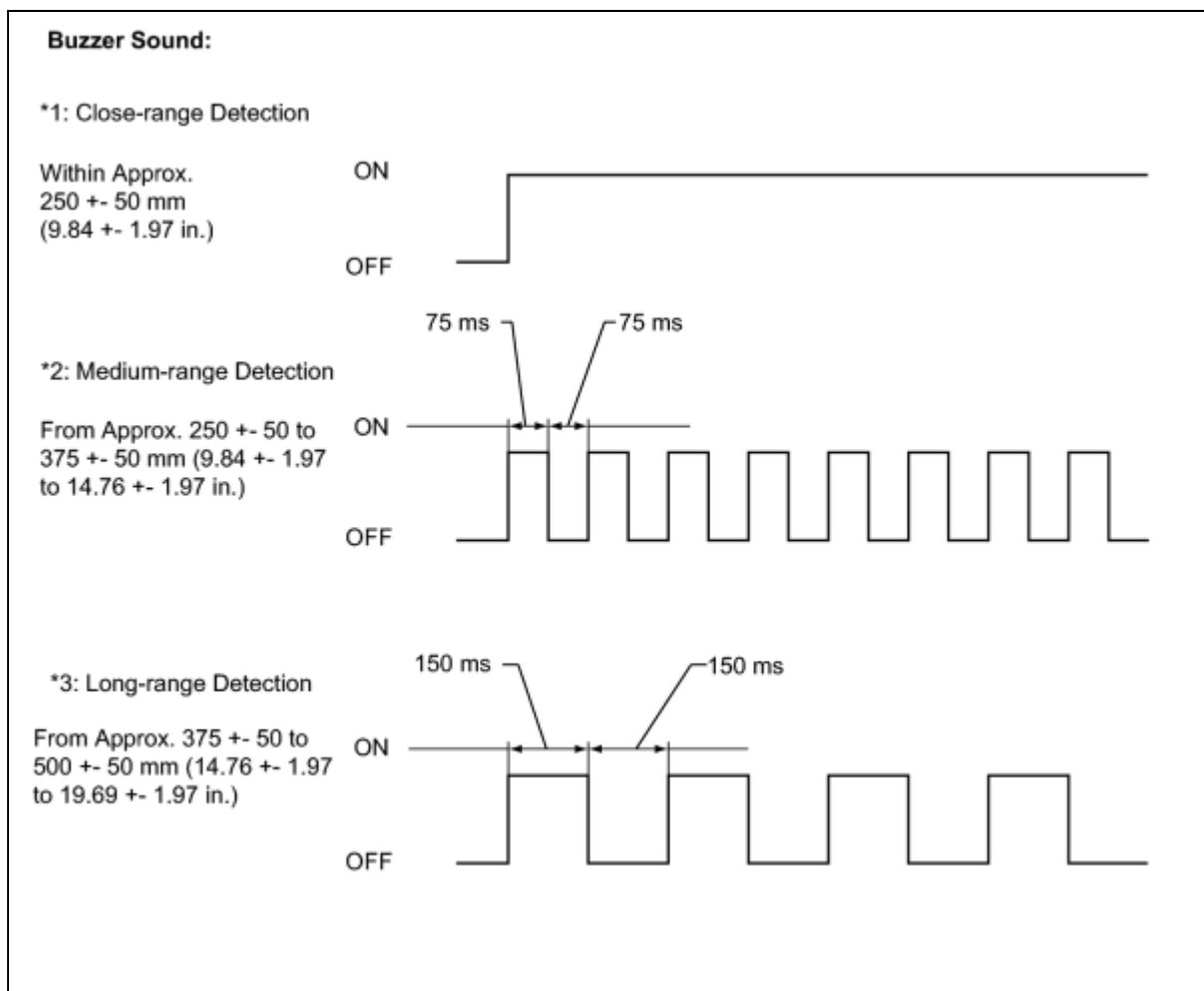
**Multi-information display (shift lever position R)**

DETECTION RANGE	DURING DETECTION
*1 Close-range detection Within approx. 250 +/- 50 mm (9.84 +/- 1.97 in.)	Buzzer: Sounds continuously Number of bars displayed: 1 (Blinking)
*2 Medium-range detection From approx. 250 +/- 50 to 375 +/- 50 mm (9.84 +/- 1.97 to 14.76 +/- 1.97 in.)	Buzzer: Sounds intermittently (ON: 75 ms / OFF: 75 ms) Number of bars displayed: 2 (illuminated)
*3 Long-range detection From approx. 375 +/- 50 to 500 +/- 50 mm (14.76 +/- 1.97 to 19.69 +/- 1.97 in.)	Buzzer: Sounds intermittently (ON: 150 ms / OFF: 150 ms) Number of bars displayed: 3 (illuminated)

Multi-display (shift lever position not in P)

DETECTION RANGE	DURING DETECTION
*1 Close-range detection Within approx. 250 +/- 50 mm (9.84 +/- 1.97 in.)	Buzzer: Sounds continuously Number of bars displayed: 1 (red illumination)
*2 Medium-range detection From approx. 250 +/- 50 to 375 +/- 50 mm (9.84 +/- 1.97 to 14.76 +/- 1.97 in.)	Buzzer: Sounds intermittently (ON: 75 ms / OFF: 75 ms) Number of bars displayed: 2 (yellow illumination)
*3 Long-range detection	Buzzer: Sounds intermittently (ON: 150 ms /

From approx. 375 +- 50 to 500 +- 50 mm (14.76 +- 1.97 to 19.69 +- 1.97 in.)

OFF: 150 ms)

Number of bars displayed: 3 (yellow illumination)

with Rear view monitor (shift lever position R)

DETECTION RANGE	DURING DETECTION
*1 Close-range detection Within approx. 250 +- 50 mm (9.84 +- 1.97 in.)	Buzzer: Sounds continuously *4: Illumination (red)
*2 Medium-range detection From approx. 250 +- 50 to 375 +- 50 mm (9.84 +- 1.97 to 14.76 +- 1.97 in.)	Buzzer: Sounds intermittently (ON: 75 ms. / OFF: 75 ms) *4: Blinking (yellow)
*3 Long-range detection From approx. 375 +- 50 to 500 +- 50 mm (14.76 +- 1.97 to 19.69 +- 1.97 in.)	Buzzer: Sounds intermittently (ON: 150 ms / OFF: 150 ms) *4: Blinking (yellow)

HINT:

- Ultrasonic waves are used to measure the detection range; however, the detection range may vary depending on the ambient temperature.
- Refer to the illustration of the display below.

(2) Check the display according to the illustration below while the buzzer is sounding.

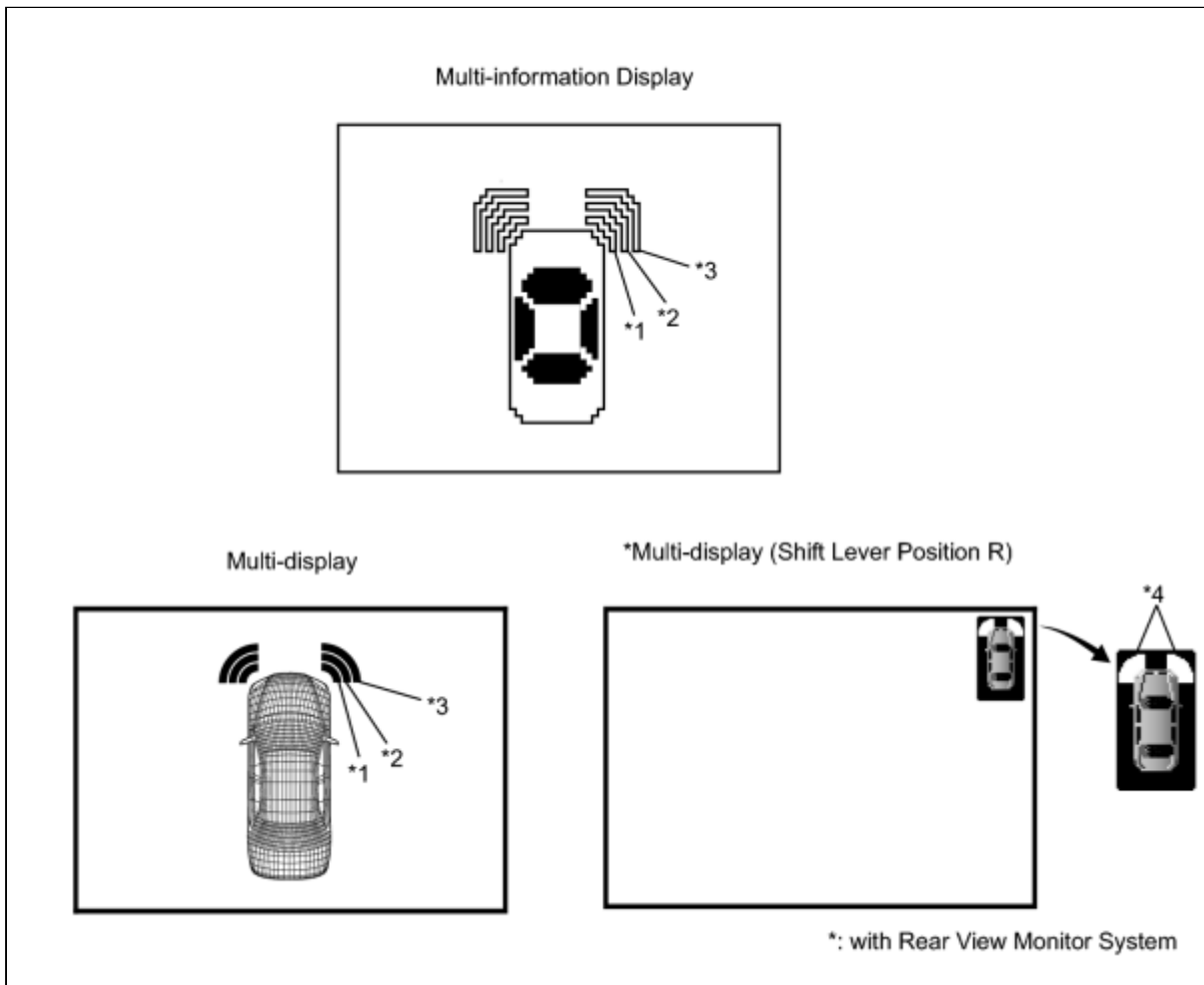

(e) When the ultrasonic sensors (back sonar) have detected an obstacle, check the display and buzzer sound.

Operation condition:

ENGINE SWITCH	CLEARANCE SONAR MAIN SWITCH	SHIFT LEVER POSITION
ON (IG)	ON	Reverse Position

(1) Check the buzzer sound according to the waveform shown in the illustration.

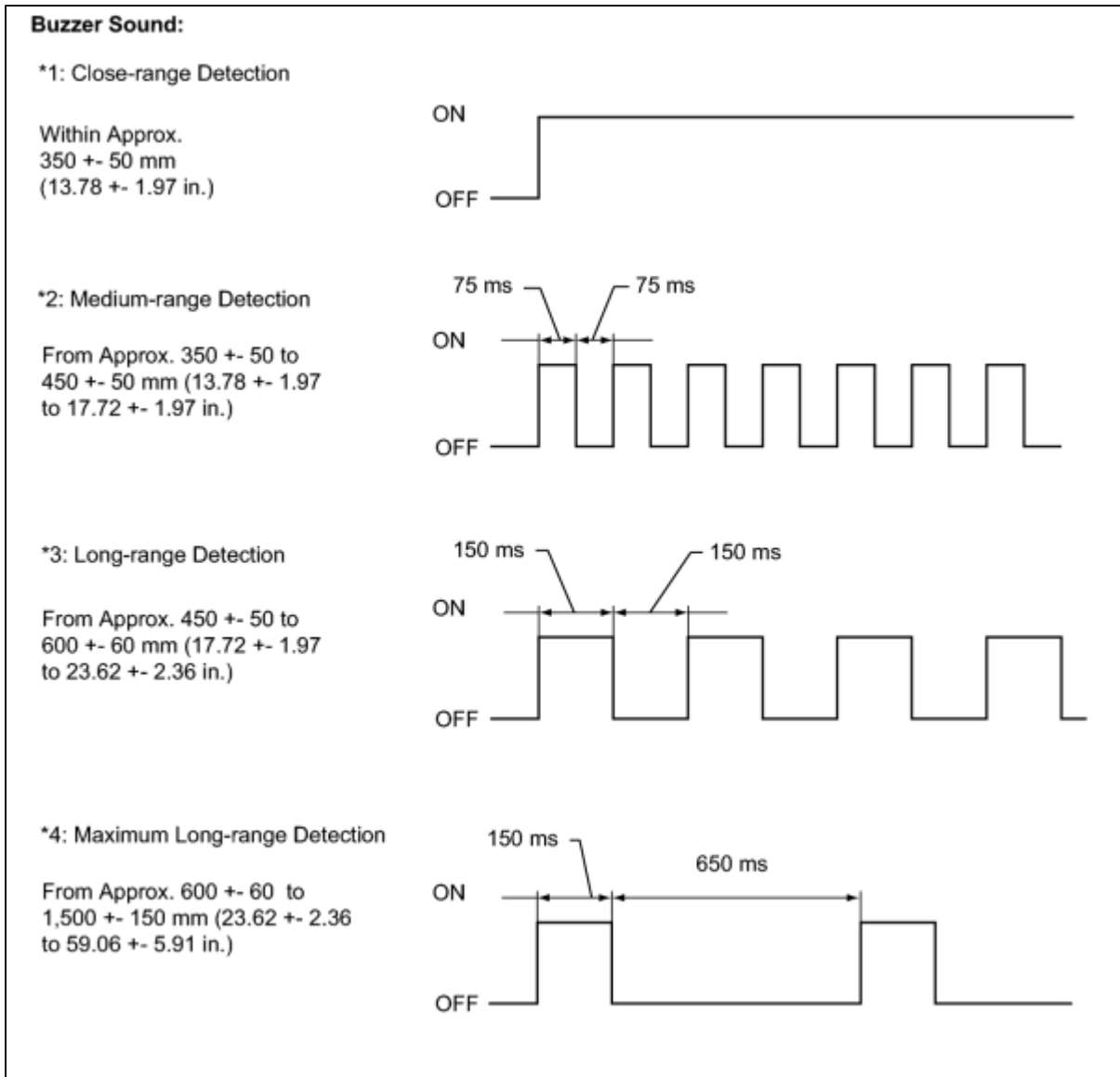
**Multi-information display (shift lever position R)**

DETECTION RANGE	DURING DETECTION
*1 Close-range detection Within approx. 350 +/- 50 mm (13.78 +/- 1.97 in.)	Buzzer: Sounds continuously Number of bars displayed: 1 (blinking)
*2 Medium-range detection From approx. 350 +/- 50 to 450 +/- 50 mm (13.78 +/- 1.97 to 17.72 +/- 1.97 in.)	Buzzer: Sounds intermittently (ON: 75 ms / OFF: 75 ms) Number of bars displayed: 2 (illuminated)
*3 Long-range detection From approx. 450 +/- 50 to 600 +/- 60 mm (17.72 +/- 1.97 to 23.62 +/- 2.36 in.)	Buzzer: Sounds intermittently (ON: 150 ms / OFF: 150 ms) Number of bars displayed: 3 (illuminated)
*4	Buzzer: Sounds intermittently (ON: 150 ms /

Maximum long-range detection From approx. 600 +- 60 to 1,500 +-150 mm (23.62 +- 2.36 to 59.06 +- 5.91 in.)	OFF: 650 ms) Number of bars displayed: 4 (illuminated)
---	---

Multi-display (shift lever position R)

DETECTION RANGE	DURING DETECTION
*1 Close-range detection Within approx. 350 +- 50 mm (13.78 +- 1.97 in.)	Buzzer: Sounds continuously Number of bars displayed: 1 (red illumination)
*2 Medium-range detection From approx. 350 +- 50 to 450 +- 50 mm (13.78 +- 1.97 to 17.72 +- 1.97 in.)	Buzzer: Sounds intermittently (ON: 75 ms / OFF: 75 ms) Number of bars displayed: 2 (yellow illumination)
*3 Long-range detection From approx. 450 +- 50 to 600 +- 60 mm (17.72 +- 1.97 to 23.62 +- 2.36 in.)	Buzzer: Sounds intermittently (ON: 150 ms / OFF: 150 ms) Number of bars displayed: 3 (yellow illumination)
*4 Maximum long-range detection From approx. 600 +- 60 to 1,500 +-150 mm (23.62 +- 2.36 to 59.06 +- 5.91 in.)	Buzzer: Sounds intermittently (ON: 150 ms / OFF: 650 ms) Number of bars displayed: 4 (yellow illumination)

with Rear view monitor (shift lever position R)

DETECTION RANGE	DURING DETECTION
*1 Close-range detection Within approx. 350 +- 50 mm (13.78 +- 1.97 in.)	Buzzer: Sounds continuously *5: Illumination (red)
*2 Medium-range detection From approx. 350 +- 50 to 450 +- 50 mm (13.78 +- 1.97 to 17.72 +- 1.97 in.)	Buzzer: Sounds intermittently (ON: 75 ms / OFF: 75 ms) *5: Blinking (yellow)
*3 Long-range detection From approx. 450 +- 50 to 600 +- 50 mm (17.72 +- 1.97 to 23.62 +- 1.97 in.)	Buzzer: Sounds intermittently (ON: 150 ms / OFF: 150 ms) *5: Blinking (yellow)
*4 Maximum long-range detection From approx. 600 +- 50 to 1,500 mm (23.62 +- 1.97 to 59.06 in.)	Buzzer: Sounds intermittently (ON: 150 ms / OFF: 650 ms) *5: Blinking (yellow)

HINT:

- Ultrasonic waves are used to measure the detection range; however, the detection range may vary depending on the ambient temperature.
 - Refer to the illustration of the display below.
- (2) Check the display according to the illustration below while the buzzer is sounding.

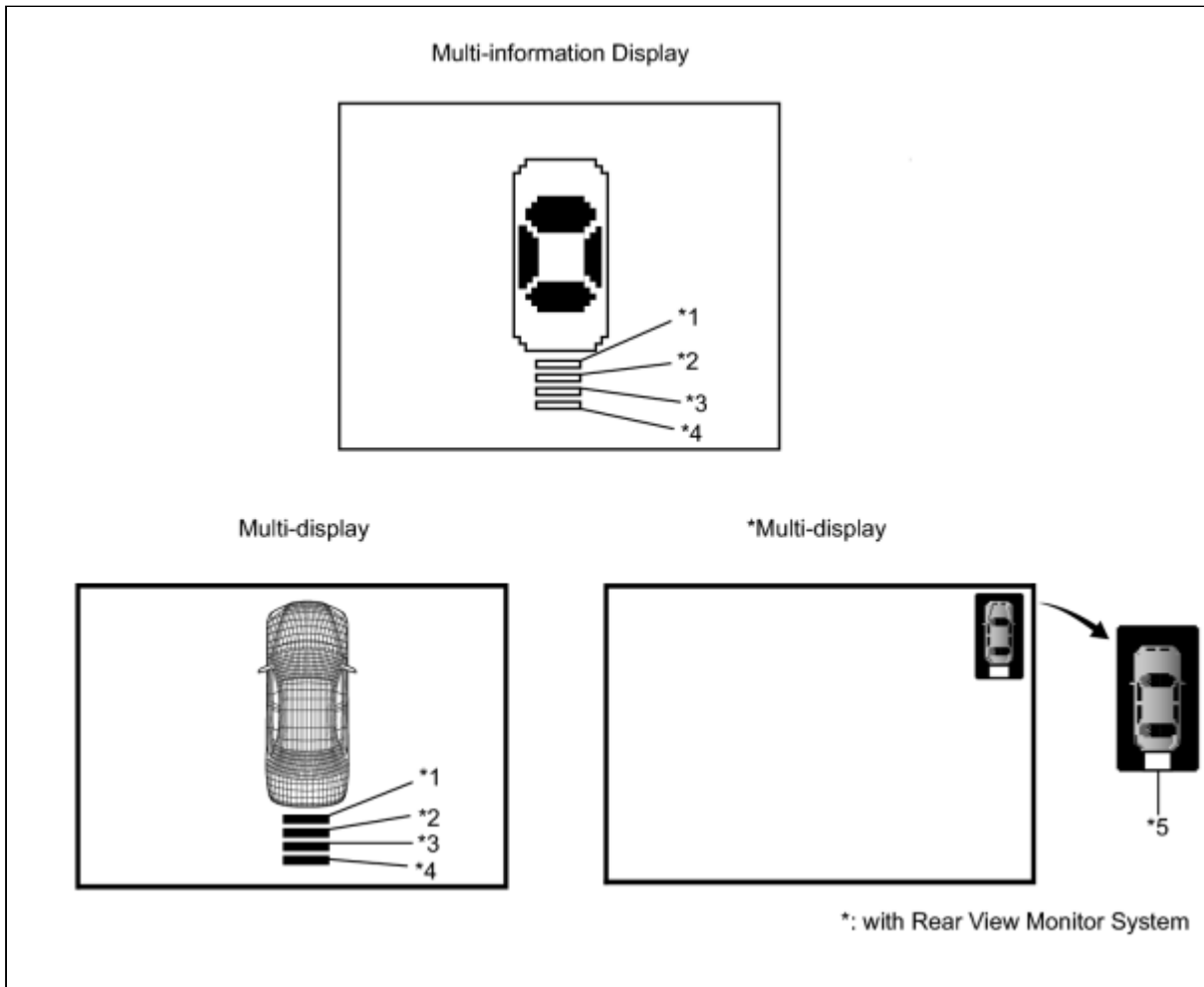

(f) When the ultrasonic sensors (rear clearance sonar) have detected an obstacle, check the display and buzzer sound.

Operation condition:

ENGINE SWITCH	CLEARANCE SONAR MAIN SWITCH	SHIFT LEVER POSITION	VEHICLE SPEED
ON (IG)	ON	Reverse Position	10 km/h (6 mph) or less

(1) Check the buzzer sound according to the waveform shown in the illustration.

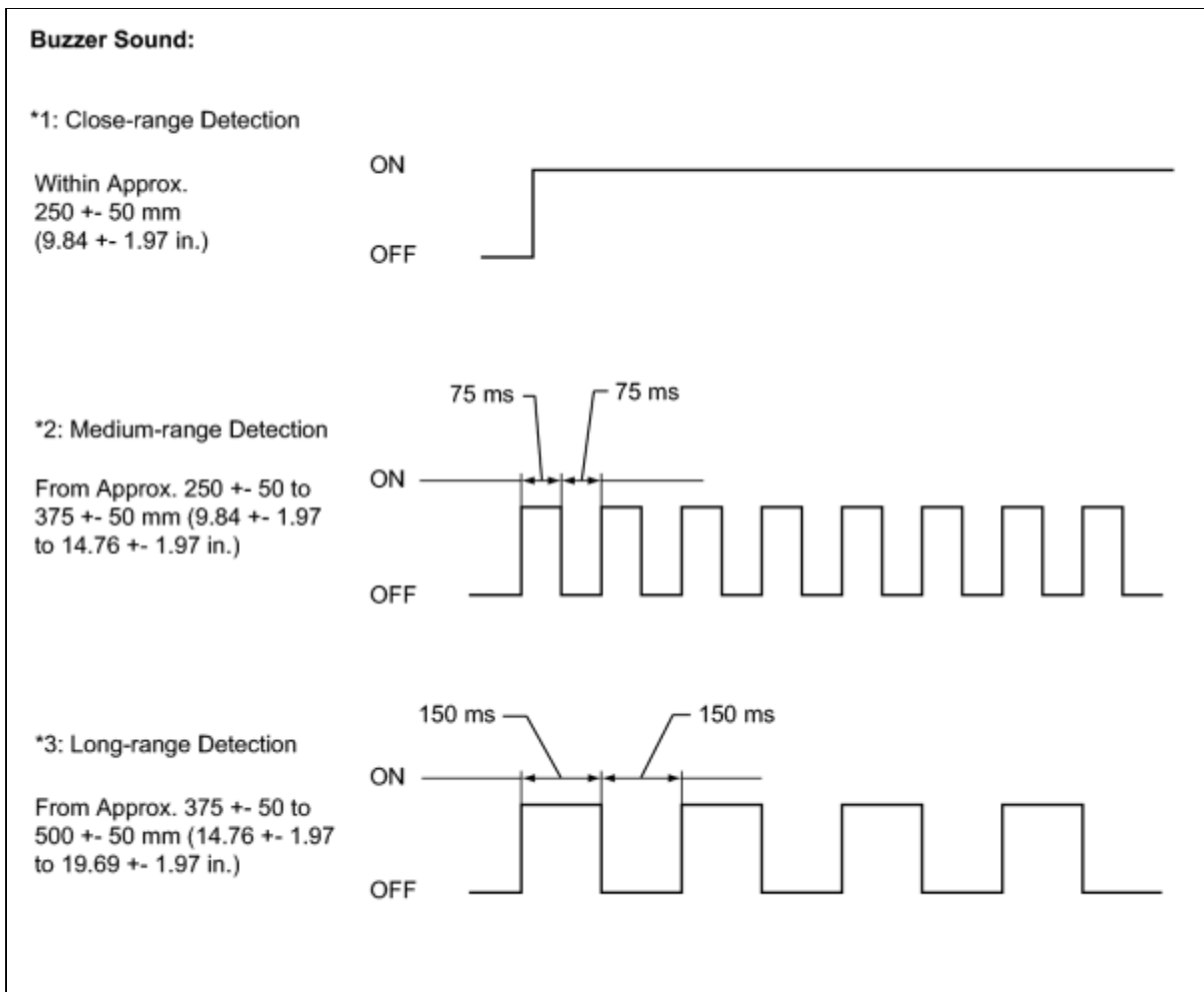

Multi-information display (shift lever position R)

DETECTION RANGE	DURING DETECTION
*1 Close-range detection Within approx. 250 +/- 50 mm (9.84 +/- 1.97 in.)	Buzzer: Sounds continuously Number of bars displayed: 1 (blinking)
*2 Medium-range detection From approx. 250 +/- 50 to 375 +/- 50 mm (9.84 +/- 1.97 to 14.76 +/- 1.97 in.)	Buzzer: Sounds intermittently (ON: 75 ms / OFF: 75 ms) Number of bars displayed: 2 (illuminated)
*3 Long-range detection From approx. 375 +/- 50 to 500 +/- 50 mm (14.76 +/- 1.97 to 19.69 +/- 1.97 in.)	Buzzer: Sounds intermittently (ON: 150 ms / OFF: 150 ms) Number of bars displayed: 3 (illuminated)

Multi-display (shift lever position R)

DETECTION RANGE	DURING DETECTION
*1 Close-range detection Within approx. 250 +/- 50 mm (9.84 +/- 1.97 in.)	Buzzer: Sounds continuously Number of bars displayed: 1 (red illumination)
*2 Medium-range detection From approx. 250 +/- 50 to 375 +/- 50 mm (9.84 +/- 1.97 to 14.76 +/- 1.97 in.)	Buzzer: Sounds intermittently (ON: 75 ms / OFF: 75 ms) Number of bars displayed: 2 (yellow illumination)
*3 Long-range detection	Buzzer: Sounds intermittently (ON: 150 ms /

From approx. 375 +- 50 to 500 +- 50 mm (14.76 +- 1.97 to 19.69 +- 1.97 in.)

OFF: 150 ms)

Number of bars displayed: 3 (yellow illumination)

with Rear view monitor (shift lever position R)

DETECTION RANGE	DURING DETECTION
*1 Close-range detection Within approx. 250 +- 50 mm (9.84 +- 1.97 in.)	Buzzer: Sounds continuously *4 : Illumination (red)
*2 Medium-range detection From approx. 250 +- 50 to 375 +- 50 mm (9.84 +- 1.97 to 14.76 +- 1.97 in.)	Buzzer: Sounds intermittently (ON: 75 ms / OFF: 75 ms) *4: Blinking (yellow)
*3 Long-range detection From approx. 375 +- 50 to 500 +- 50 mm (14.76 +- 1.97 to 19.69 +- 1.97 in.)	Buzzer: Sounds intermittently (ON: 150 ms / OFF: 150 ms) *4: Blinking (yellow)

HINT:

- Ultrasonic waves are used to measure the detection range; however, the detection range may vary depending on the ambient temperature.
- Refer to the illustration of the display below.

(2) Check the display according to the illustration below while the buzzer is sounding.

