

REPLACEMENT

HINT:

- The installation procedures are the removal procedures in reverse order. However, only installation procedures requiring additional information are included.
- A bolt without a torque specification is shown in the standard bolt chart (see page 03-2).

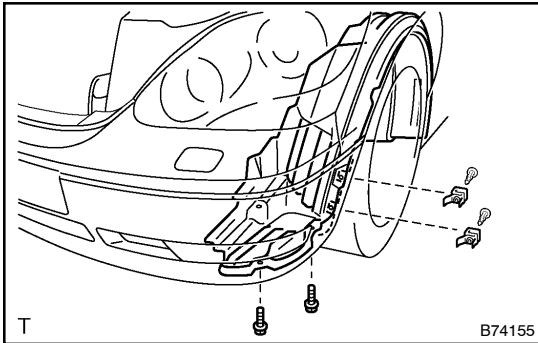

1. REMOVE FRONT FENDER LINER LH

- Remove the 2 screws and 2 clips.
- Partially remove the fender liner.

HINT:

It is not necessary to fully remove the fender liner completely. Partially remove it so that the bumper cover can be removed in step (5).

2. REMOVE FRONT FENDER LINER RH

HINT:

Use the same procedure described for the LH side.

3. REMOVE RADIATOR SIDE DEFLECTOR LH

- Remove the 3 clips and deflector.

4. REMOVE RADIATOR SIDE DEFLECTOR RH

- Remove the 3 clips and deflector.

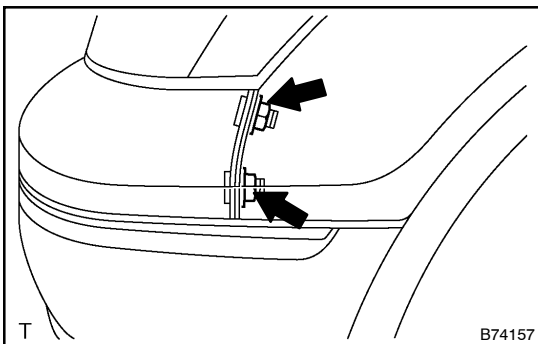

5. REMOVE FRONT BUMPER COVER

- Remove the 4 nuts.

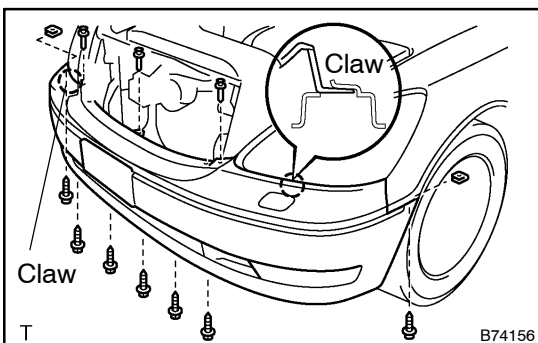

- Remove the 3 clips and 7 screws.
- Using a screwdriver, disengage the 2 claws and remove the bumper cover.
- Disconnect the 2 fog lamp connectors.
- w/ Clearance sonar system:
Disconnect the 6 sensor connectors.

6. REMOVE HEADLAMP CLEANER (FROM MOTOR TO JOINT) HOSE (W/ HEADLAMP CLEANER)

- (a) Disconnect the cleaner hose joint from the actuator.

HINT:

Be careful when removing the cleaner hose from the actuator, because washer fluid will spill.

- (b) Disconnect the cleaner hose from the bumper cover.

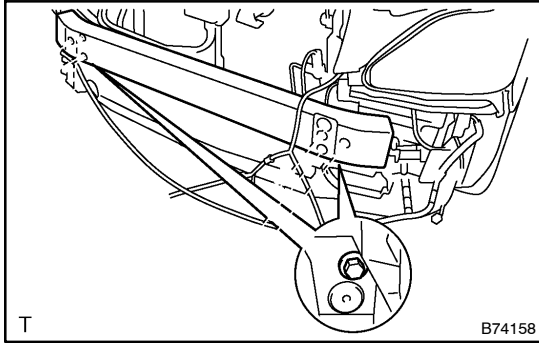
7. REMOVE FRONT BUMPER ENERGY ABSORBER**8. REMOVE RADIATOR SUPPORT REINFORCEMENT LOWER**

- (a) Remove the 2 bolts.
 (b) Unlock the 2 claws and partially remove the reinforcement lower by angling it towards yourself.

HINT:

It is not necessary to fully remove the reinforcement lower completely. Partially remove it so that the bumper reinforcement can be removed in step (9).

9. REMOVE FRONT BUMPER REINFORCEMENT SUB-ASSY

- (a) Remove the 6 bolts and reinforcement.

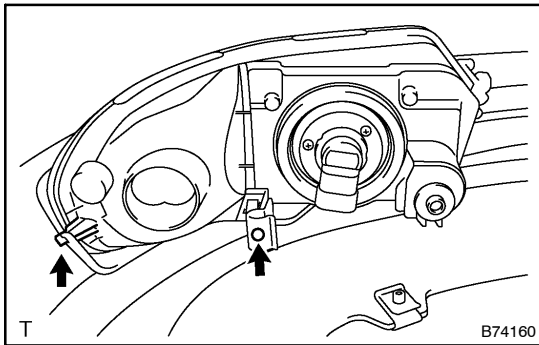
10. REMOVE LASER SENSOR (W/ RADAR CRUISE)**11. REMOVE FOG LAMP ASSY LH**

- (a) Using a screwdriver, disengage the 2 claws and remove the fog lamp.

HINT:

Tape the screwdriver tip before use.

12. REMOVE FOG LAMP ASSY RH

HINT:

Use the same procedures described for the LH side.

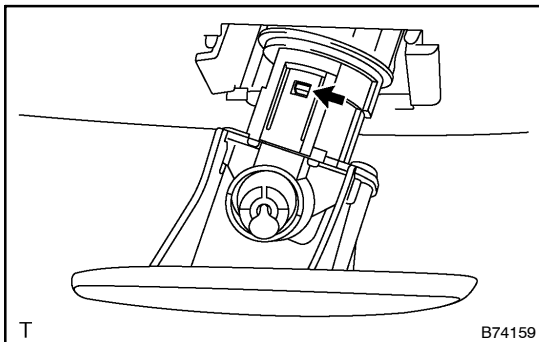
**13. REMOVE HEADLAMP CLEANER WASHER NOZZLE (W/ HEADLAMP CLEANER)**

- (a) Using a screwdriver, pull out the 2 washer nozzles.

HINT:

Tape the screwdriver tip before use.

14. REMOVE HEADLAMP WASHER ACTUATOR SUB-ASSY LH (W/ HEADLAMP CLEANER)

(a) Remove the screw and actuator.

15. REMOVE HEADLAMP WASHER ACTUATOR SUB-ASSY RH (W/ HEADLAMP CLEANER)

(a) Remove the screw and actuator.

16. REMOVE ULTRASONIC SENSOR NO.1 (w/ CLEARANCE SONAR SYSTEM)

(a) Using a screwdriver, remove the retainer and sensor.

HINT:

Tape the screwdriver tip before use.

17. REMOVE FRONT BUMPER EXTENTION MOUNTING BRACKET

(a) Remove the 2 screws and mounting bracket.

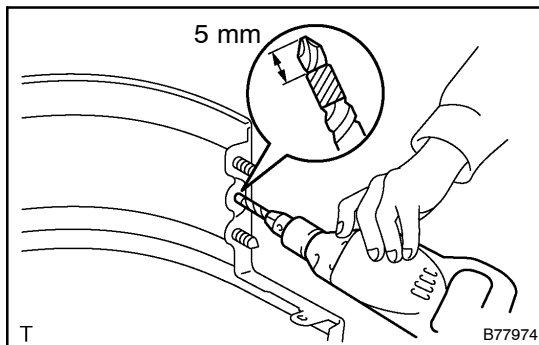
**18. REMOVE FRONT BUMPER SIDE RETAINER LH**(a) Use a drill that has a tip of less than ϕ 4 mm (0.16 in.).

(b) Tape the drill tip as shown in the illustration.

Dimension: 5 mm (0.20 in.)

HINT:

Taping the drill tip is done to prevent excessive drilling.

(c) Gently place the drill tip onto the rivet, cut the rivet flanges and then remove the rivet.

NOTICE:

- **Pressing the drill tip onto the rivet strongly will cause the rivet to turn with the drill and the rivet will not be cut.**
 - **Do not prize the rivet hole with the drill. Doing so may damage the rivet hole and/or the drill.**
 - **Be careful as the cut rivet will be very hot.**
- (d) Remove the retainer from the bumper cover.

19. REMOVE FRONT BUMPER SIDE RETAINER RH

HINT:

Use the same procedures described for the LH side.

20. REMOVE FRONT BUMPER MOULDING

HINT:

Remove the double-sided tape completely from the bumper. Double-sided tape interferes with the installation of the moulding to the bumper.

21. REMOVE FRONT BUMPER SIDE SEAL LH

(a) Using a screwdriver, disengage the 4 claws and remove the side seal.

HINT:

Tape the screwdriver tip before use.

22. REMOVE FRONT BUMPER SIDE SEAL RH (W/O RADAR CRUISE)

HINT:

Use the same procedures described for the LH side.

23. REMOVE FRONT BUMPER HOLE COVER LH

(a) Using a screwdriver, disengage the 2 claws and remove the hole cover.

HINT:

Tape the screwdriver tip before use.

24. REMOVE FRONT BUMPER HOLE COVER RH (W/ RADAR CRUISE)

(a) Using a screwdriver, disengage the 4 claws and remove the hole cover.

HINT:

Tape the screwdriver tip before use.

25. INSTALL FRONT BUMPER REINFORCEMENT SUB-ASSY

- (a) Install the reinforcement with the 6 bolts.

Torque: 12.5 N·m (130 kgf·cm, 9 ft·lbf)

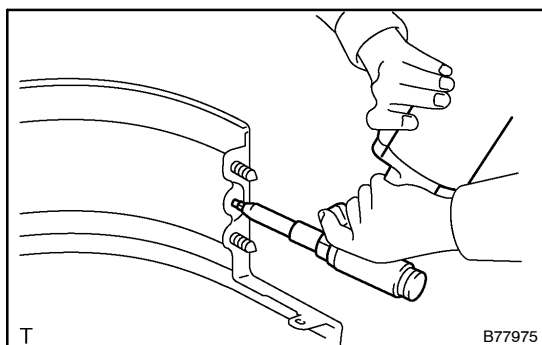
**26. INSTALL FRONT BUMPER SIDE RETAINER LH**

- (a) Using an air riveter or hand riveter with nose piece, strike waterproof rivets of ϕ 4.9 mm (0.19 in.) into the side retainer to install the rivet to the bumper cover.

NOTICE:

If the rivet is not positioned perpendicularly to the bumper, the mandrel will bend and become damaged.

27. INSTALL FRONT BUMPER SIDE RETAINER RH**HINT:**

Use the same procedures described for the LH side.