

# REPLACEMENT

HINT:

COMPONENTS: See page 71-8

## 1. TABLE OF BOLT, SCREW AND NUT

HINT:

The bolts, screws and nuts, which are necessary for installation and removal of the instrument panel, are shown in the illustration below with alphabets.

mm (in.) (L = Length)

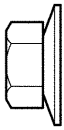
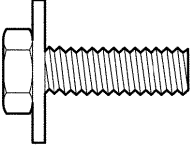
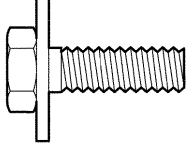
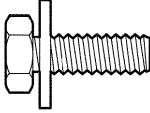
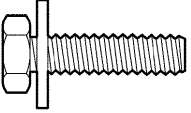
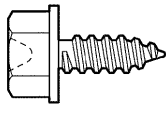
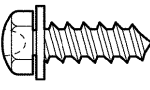
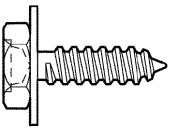
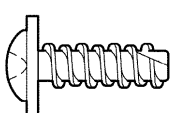
Code	Shape	Code	Shape	Code	Shape
<A>	 $\phi = 6$ (0.24)	<B>	 $\phi = 8$ (0.31) L = 24 (0.94)	<C>	 $\phi = 6$ (0.24) L = 20 (0.79)
	B51290 90179-06097		B50935 90119-08B72		B50534 91635-60620
<D>	 $\phi = 6$ (0.24) L = 16 (0.63)	<E>	 $\phi = 6$ (0.24) L = 18 (0.71)	<F>	 $\phi = 5$ (0.20) L = 14 (0.55)
	B62758 91635-G0616		B62758 91635-G0618		90159-50138
<G>	 $\phi = 5$ (0.20) L = 16 (0.63)	<H>	 $\phi = 5$ (0.20) L = 18 (0.71)	<I>	 $\phi = 5$ (0.20) L = 14 (0.55)
	90159-50105		B62761 90159-50311		B50620 93568-55014

B66079

2. DISCONNECT BATTERY NEGATIVE TERMINAL (See page 60-1)
3. REMOVE SHIFT LEVER KNOB SUB-ASSY
4. REMOVE SHIFT LEVER KNOB SUB-ASSY

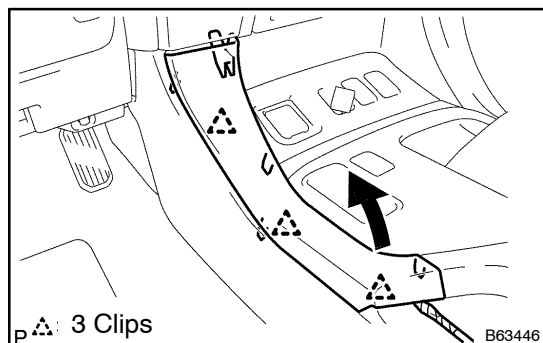

5. REMOVE CONSOLE UPPER PANEL GARNISH NO.2
  - (a) Disengage the 3 clips and remove the console upper panel garnish No.2.

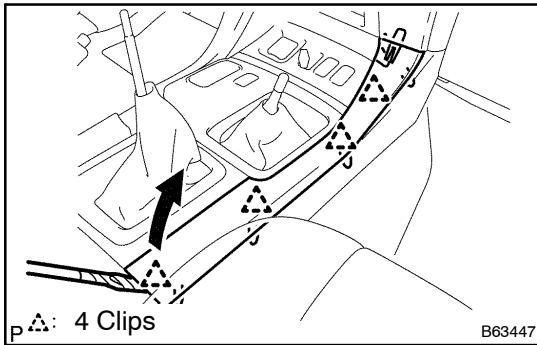

- 6. REMOVE CONSOLE UPPER PANEL GARNISH NO.1**  
 (a) Disengage the 4 clips and remove the console upper panel garnish No.1.

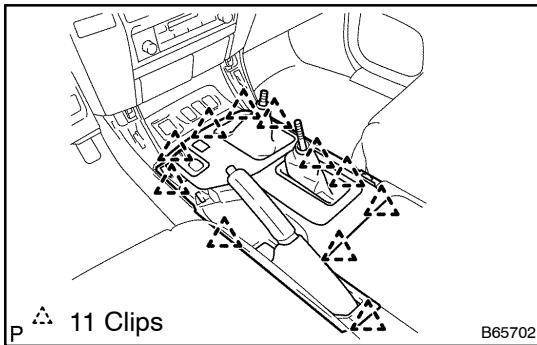

- 7. REMOVE CONSOLE PANEL UPPER ASSY**  
 (a) Disengage the 11 clips and remove the console panel upper assy, then disconnect the connectors.

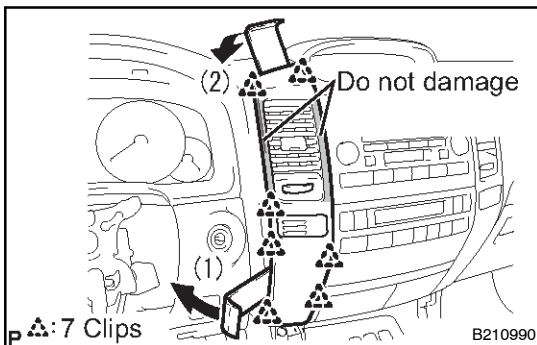

- 8. REMOVE INSTRUMENT PANEL GARNISH SUB-ASSY LH**  
 (a) Using a moulding remover, disengage the bottom 2 clips.  
 (b) Using a moulding remover, disengage the top 2 clips.  
 (c) While wiggling the center part, disengage the center 3 clips carefully.  
 (d) Disconnect the connector and remove the instrument panel garnish sub-assy LH.

**9. REMOVE INSTRUMENT PANEL GARNISH SUB-ASSY RH**

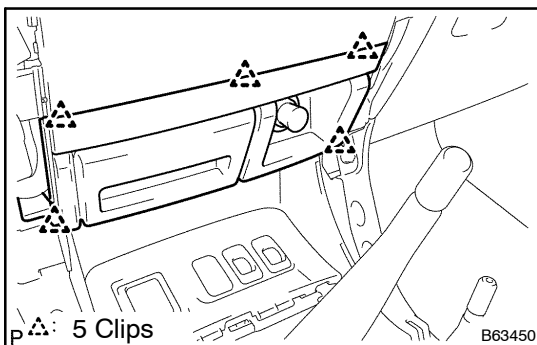

- 10. REMOVE INSTRUMENT CLUSTER FINISH PANEL CENTER LOWER**  
 (a) Disengage the 5 clips and remove the instrument cluster finish panel center lower, then disconnect the connectors.

**11. REMOVE INTEGRATION CONTROL & PANEL ASSY (See page 55-12)**

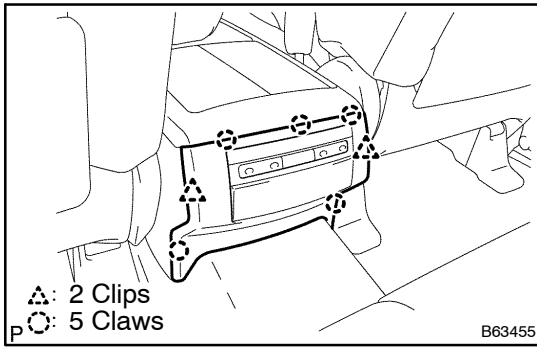

- 12. REMOVE CONSOLE REAR END PANEL SUB-ASSY**
- Disengage the 2 clips and the 5 claws, and then remove the console rear end panel sub-assy.
  - Disconnect the connectors.

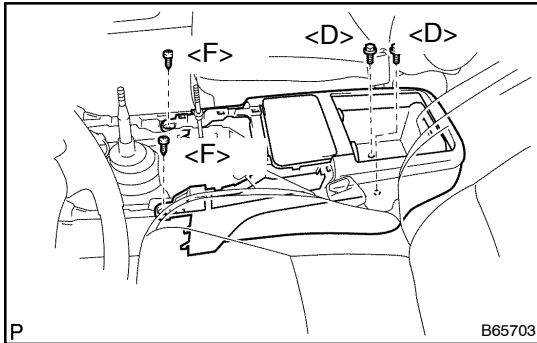

- 13. REMOVE RR CONSOLE BOX ASSY**
- Remove the 2 bolts <D>, the 2 screws <F> and the RR console box assy.

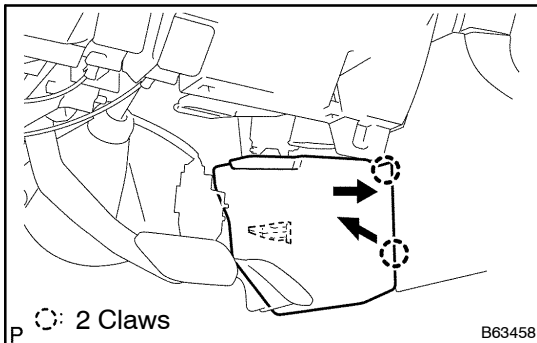

- 14. REMOVE CONSOLE BOX INSERT FRONT NO.2**
- Disengage the 2 claws.
  - Pull the console box insert front No. 2 rearward to remove it.

**15. REMOVE CONSOLE BOX INSERT**

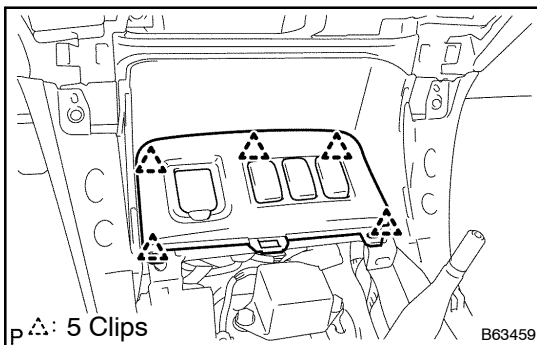

- 16. REMOVE CONSOLE UPPER PANEL GARNISH FRONT**
- Disengage the 5 clips and remove the console upper panel garnish front, then disconnect the connectors.

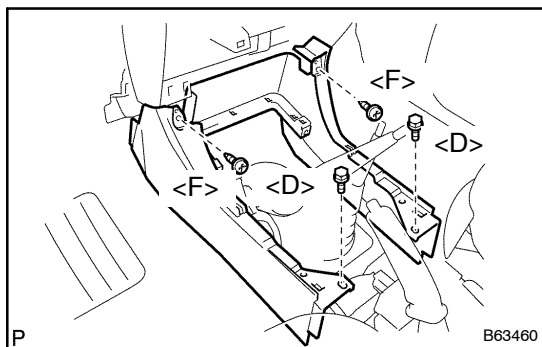
**17. REMOVE CONSOLE BOX LOWER**

- (a) Remove the 2 bolts <D>.
- (b) Remove the 2 screws <F> and the console box lower.

**18. REMOVE STEERING WHEEL COVER LOWER NO.2****19. REMOVE STEERING WHEEL COVER LOWER NO.3****20. REMOVE HORN BUTTON ASSY (See page 60-17)****21. REMOVE STEERING WHEEL ASSY (See page 50-8)**

SST 09950-50013 (09951-05010, 09952-05010, 09953-05020, 09954-05021)

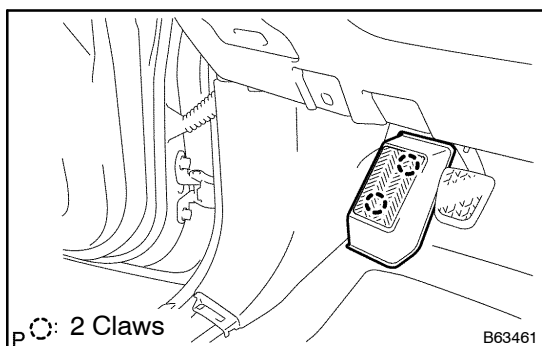
**22. REMOVE STEERING COLUMN COVER (See page 50-8)****23. REMOVE TURN SIGNAL SWITCH ASSY W/SPIRAL CABLE SUB-ASSY (See page 50-8)****24. REMOVE FRONT DOOR SCUFF PLATE LH (See page 76-38)****25. REMOVE FRONT DOOR SCUFF PLATE RH (See page 76-38)****26. REMOVE FRONT FLOOR FOOTREST**

- (a) Disengage the 2 claws and remove the front floor footrest.

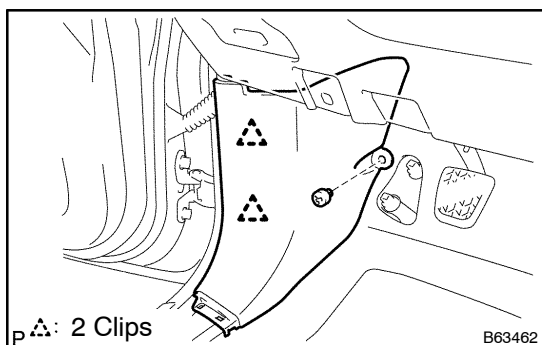
**27. REMOVE COWL SIDE TRIM BOARD LH**

- (a) Remove the clip.
- (b) Disengage the 2 clips and remove the cowl side trim board LH.

**28. REMOVE COWL SIDE TRIM BOARD RH**

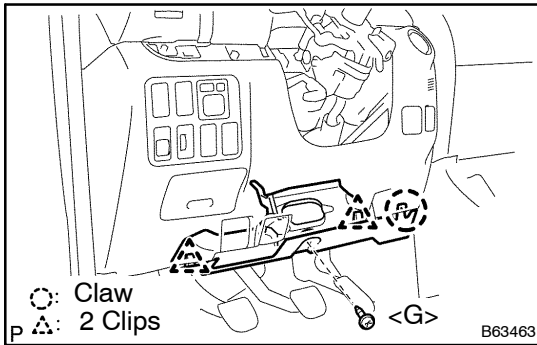

### 29. REMOVE INSTRUMENT PANEL UNDER COVER SUB-ASSY NO.1

- (a) Remove the screw <G>.
- (b) Disengage the 2 clips and the claw, and then remove the instrument panel under cover sub-assy No.1.

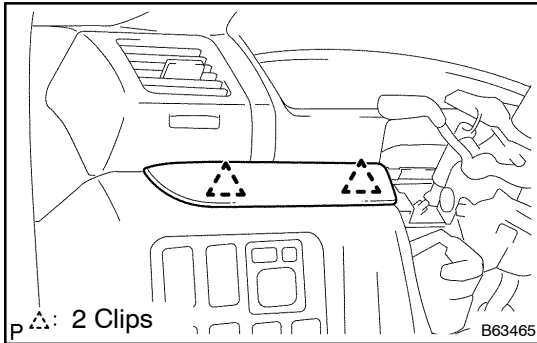

### 30. REMOVE INSTRUMENT CLUSTER FINISH PANEL ORNAMENT

- (a) Disengage the 2 clips and remove the instrument cluster finish panel ornament.

### 31. REMOVE SWITCH HOLE BASE NO.1

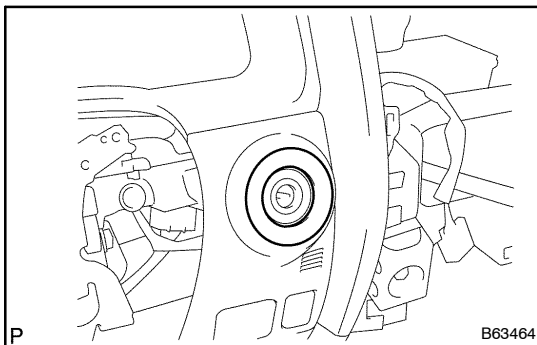

### 32. REMOVE INSTRUMENT PANEL FINISH PLATE

- (a) Remove the instrument panel finish plate.

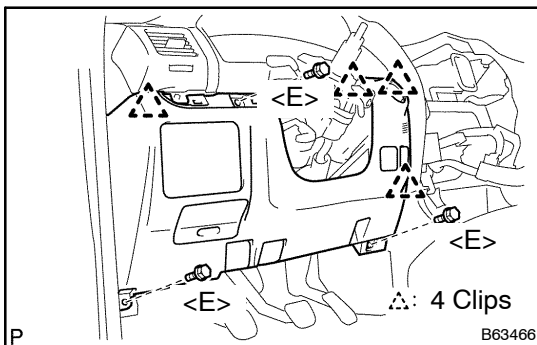

### 33. REMOVE INSTRUMENT PANEL FINISH LOWER PANEL RH

- (a) Remove the 3 bolts <E>.
- (b) Disconnect the hood lock control cable assy and the fuel lid lock control cable sub-assy.
- (c) Disengage the 4 clips.
- (d) Disconnect the connectors and remove the instrument panel finish lower panel RH.

### 34. REMOVE INSTRUMENT PANEL LOWER LH

- (a) Remove the 3 bolts <E> and instrument panel lower LH.

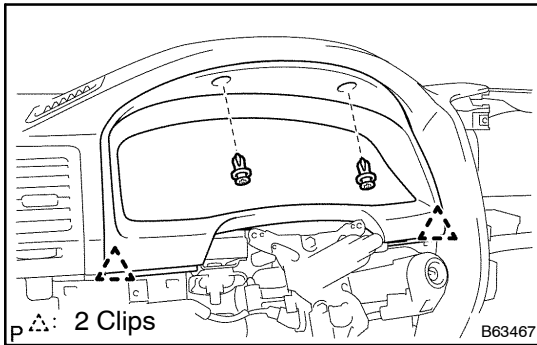

### 35. REMOVE INSTRUMENT CLUSTER FINISH PANEL SUB-ASSY

- (a) Remove the 2 clips.
- (b) Disengage the 2 clips and remove the instrument cluster finish panel sub-assy.

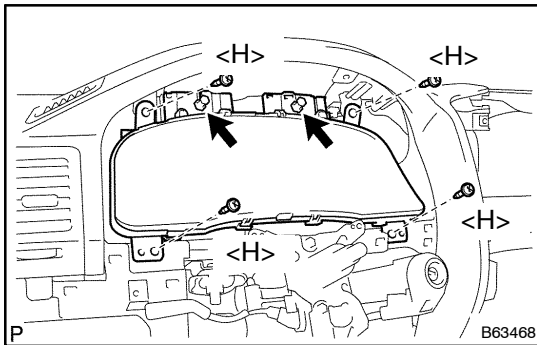

### 36. REMOVE COMBINATION METER ASSY

- (a) Remove the 4 screws <H>.
- (b) Loosen the 2 bolts and remove the combination meter assy.

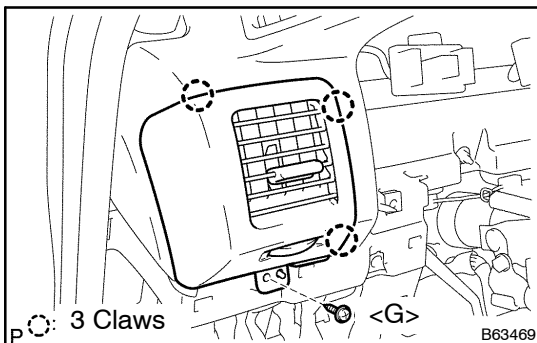

### 37. REMOVE INSTRUMENT PANEL REGISTER ASSY NO.1

- (a) Remove the screw <G>.
- (b) Disengage the 3 claws and remove the instrument panel register assy No.1.

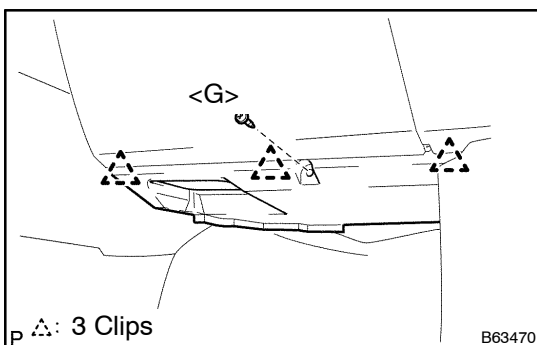

### 38. REMOVE INSTRUMENT PANEL UNDER COVER NO.2

- (a) Remove the screw <G>.
- (b) Disengage the 3 clips and remove the instrument panel under cover No.2.

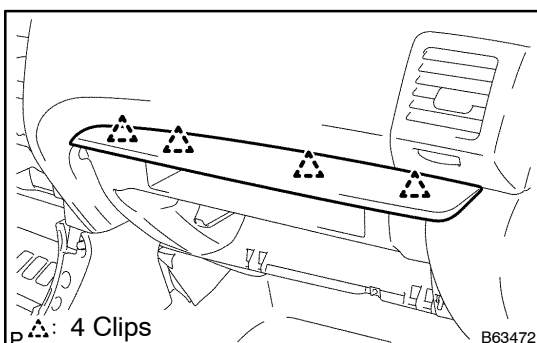

### 39. REMOVE INSTRUMENT PANEL ORNAMENT

- (a) Disengage the 4 clips and remove the instrument panel ornament.

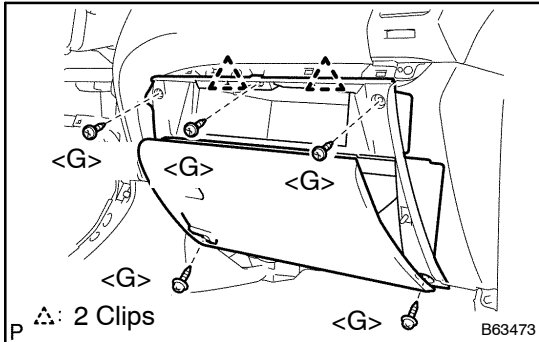
**40. DISCONNECT PASSENGER AIRBAG CONNECTOR (See page 60-28)****41. REMOVE GLOVE COMPARTMENT DOOR ASSY**

- (a) Remove the 5 screws <G>.
- (b) Disengage the 2 clips and remove the glove compartment door assy, then disconnect the connectors.

**42. REMOVE INSTRUMENT PANEL REGISTER ASSY NO.2****43. REMOVE DISC PLAYER CHANGER W/BACKET (W/ DISC PLAYER CHANGER)  
(See page 67-26)****44. REMOVE ASSIST GRIP ASSY (See page 76-38)****45. REMOVE FRONT PILLAR GARNISH LH (See page 76-38)****46. REMOVE FRONT PILLAR GARNISH RH (See page 76-38)**

**47. REMOVE INSTRUMENT PANEL SAFETY PAD SUB-ASSY W/DEFROSTER NOZZLE DUCT**

- (a) Remove the 9 bolts <C> <E> and nut <A>.
- (b) Disconnect the connectors.
- (c) Remove the instrument panel safety pad sub-assy w/ defroster nozzle duct.

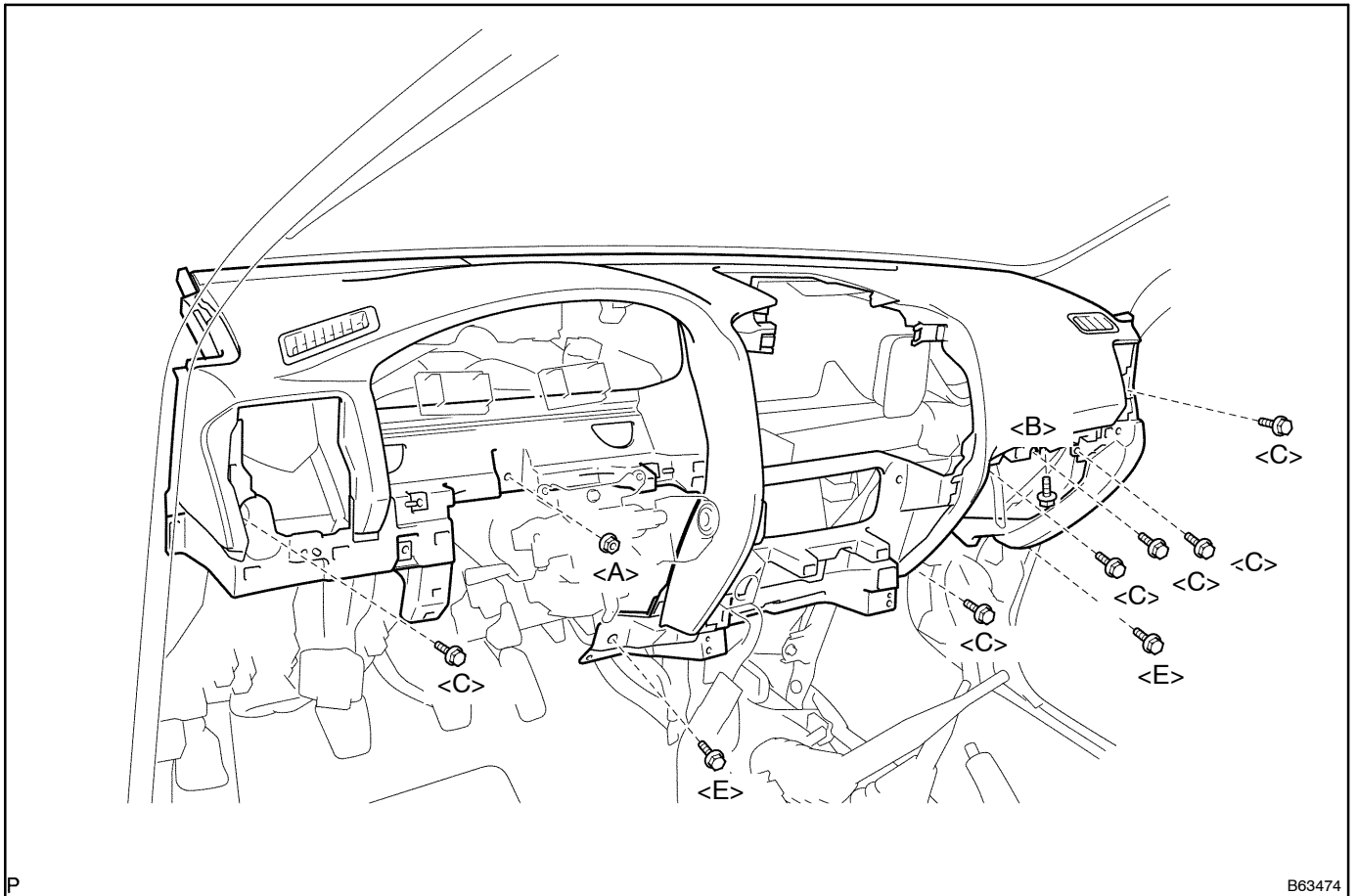
**48. REMOVE DEFROSTER NOZZLE ASSY**

- (a) Remove the 5 screws <l> and defroster nozzle assy.

**49. REMOVE HEATER TO REGISTER DUCT NO.3**

- (a) Remove the 2 screws <l> and heater to register duct No.3.

**50. REMOVE SIDE DEFROSTER NOZZLE DUCT NO.1****51. REMOVE SIDE DEFROSTER NOZZLE DUCT NO.2****52. REMOVE AUTOMATIC LIGHT CONTROL SENSOR****53. REMOVE INSTRUMENT PANEL WIRE NO.3****54. REMOVE CONNECTOR NO.2 HOLDER****55. REMOVE INSTRUMENT PANEL SPEAKER PANEL SUB-ASSY NO.1 (W/ 12 SPEAKER)****56. REMOVE STEREO COMPONENT SPEAKER ASSY FRONT (W/ 12 SPEAKER)**

(See page [67-18](#))

**57. REMOVE ANTENNA CORD SUB-ASSY (See page [67-30](#))****58. REMOVE NAVIGATION ANTENNA ASSY (W/ NAVIGATION SYSTEM) (See page [67-36](#))****59. REMOVE INSTR PNL PASS L/DOOR AIR BAG ASSY (See page [60-28](#))****60. REMOVE INSTRUMENT PANEL SAFETY PAD SUB-ASSY****61. INSTALL INSTR PNL PASS L/DOOR AIR BAG ASSY (See page [60-28](#))**



**62. INSTALL INSTRUMENT PANEL SAFETY PAD SUB-ASSY W/DEFROSTER NOZZLE DUCT**

- (a) Using a torque wrench, install the bolt <B>.

**Torque: 20 N·m (204 kgf·cm, 14 ft·lbf)**

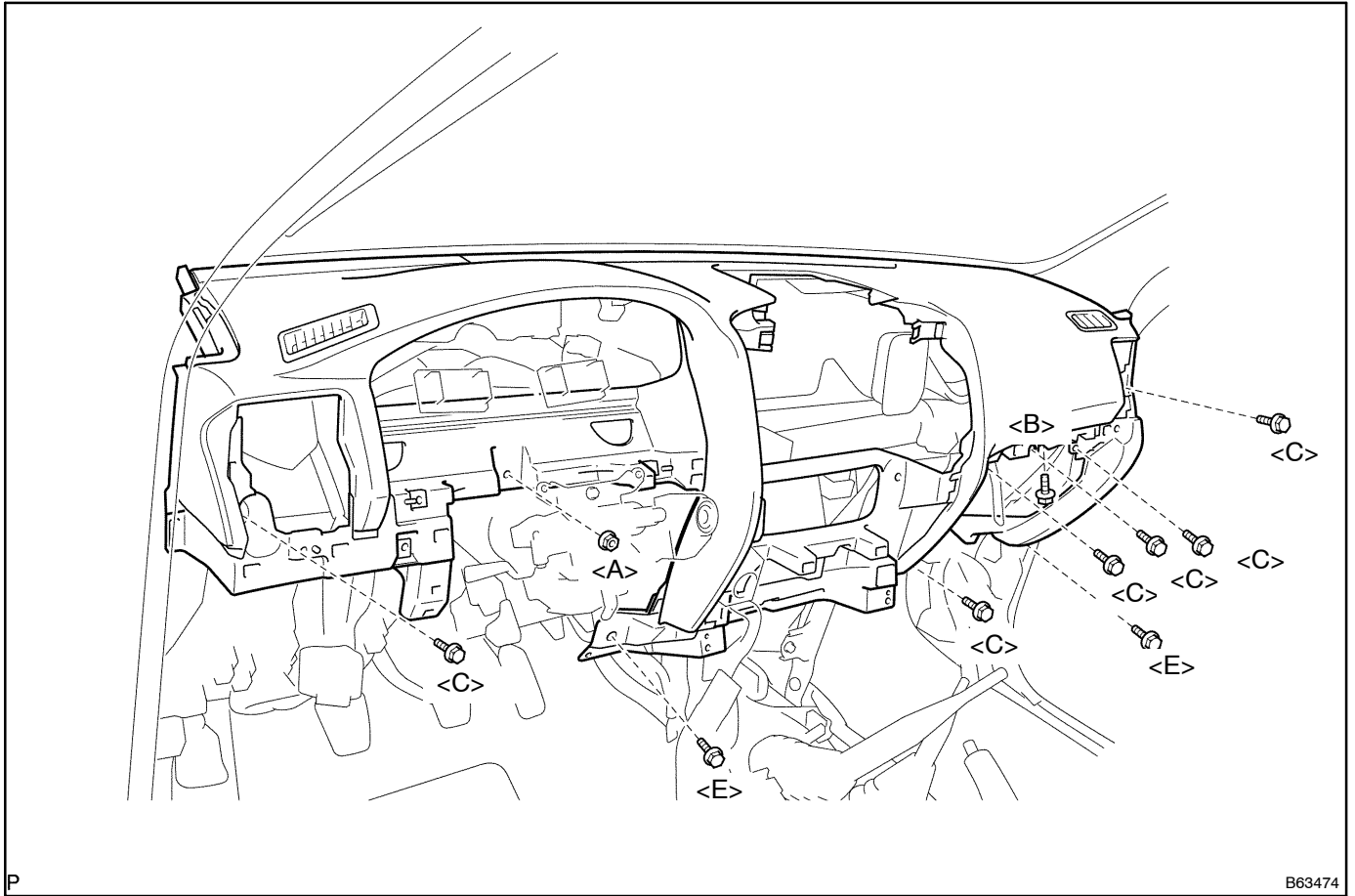

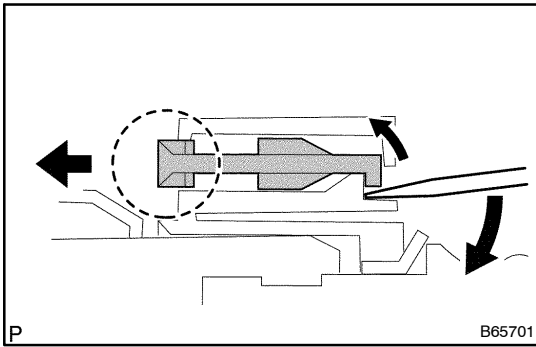
**63. INSTALL COMBINATION METER ASSY**

- (a) Pull the check pin backward while pressing the check pin with a flat-head screwdriver as shown in the illustration.
- (b) Check that the wire harness connector is engaged in the instrument panel safety pad installation position.
- (c) Install the 4 screws in order as shown in the illustration.
- (d) Tighten the 2 connector fitting bolts until a clicking sound can be heard.
- (e) After tightening, check that the check pin protrudes.

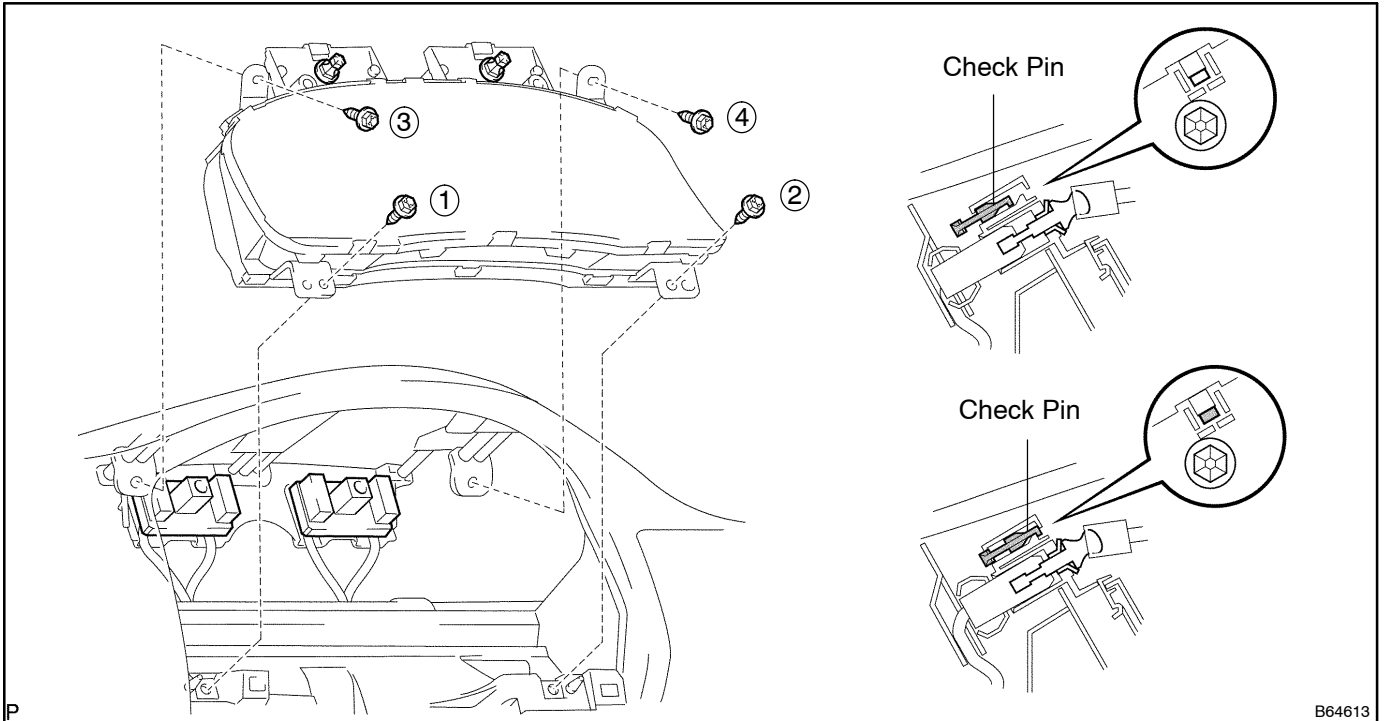

64. ADJUST SPIRAL CABLE SUB-ASSY (See page 60-25)
65. INSTALL STEERING WHEEL ASSY (See page 50-8)
66. INSTALL HORN BUTTON ASSY (See page 60-17)
67. INSPECT HORN BUTTON ASSY (See page 60-11)
68. INCLINATION SENSOR ZERO DEGREE CORRECTION (See page 71-23)
69. INSPECT SRS WARNING LIGHT (See page 05-973)